

EMC Test Report

Application No. : LH-230711011752

Applicant : Yuyao Yuanxin Vehicle Equipment Co., Ltd

Equipment Under Test (EUT)

EUT Name : Integrated machine

Model No. : YX1715

Serial No. : See page 3

Brand Name : N/A

Receipt Date : 2023-06-29

Test Date : 2023-06-29 to 2023-07-04

Issue Date : 2023-07-10

Standards : EN IEC 55014-1: 2021
EN IEC 55014-2: 2021

Conclusions : **PASS**

In the configuration tested, the EUT complied with the standards specified above. The EUT technically complies with the 2014/30/EU directive requirements.

Test/Witness Engineer : *York xin*

Approved & Authorized : *Jack su*



This report details the results of the testing carried out on one sample. The results contained in this test report do not relate to other samples of the same product. The manufacturer should ensure that all products in series production are in conformity with the product sample detailed in the report.

TABLE OF CONTENTS

1. General Information	3
1.1. Client Information	3
1.2. General Description of EUT (Equipment Under Test)	3
1.3. Block Diagram Showing the Configuration of System Tested	3
1.4. Description of Support Units	3
1.5. Performance Criterion	4
1.6. Classification of Apparatus	4
1.7. Test Facility	4
2. Test Results Summary	5
3. Test Equipment Used	6
4. Conducted Emission Test	8
4.1. Test Standard and Limit	8
4.2. Test Setup	8
4.3. Test Procedure	8
4.4. Test Condition	9
4.5. Test Data	9
5. Radiated Emission Test	12
5.1. Test Standard and Limit	12
5.2. Test Setup	12
5.3. Test Procedure	12
5.4. Test Condition	13
5.5. Test Data	13
6. Electrostatic Discharge Immunity Test	16
6.1. Test Requirements	16
6.2. Test Setup	16
6.3. Test Procedure	16
6.4. Test Data	17
7. Radiated Electromagnetic Field Immunity test	19
7.1. Test Requirements	19
7.2. Test Setup	19
7.3. Test Procedure	19
7.4. Test Data	20
8. Photographs - Constructional Details	22

1. General Information

1.1. Client Information

Applicant	:	Yuyao Yuanxin Vehicle Equipment Co., Ltd
Address	:	No. 33, Weiliu Road, Industrial Functional Zone, Simen Town, Yuyao City, Zhejiang Province
Manufacturer	:	Yuyao Yuanxin Vehicle Equipment Co., Ltd
Address	:	No. 33, Weiliu Road, Industrial Functional Zone, Simen Town, Yuyao City, Zhejiang Province

1.2. General Description of EUT (Equipment Under Test)

EUT Name	:	Integrated machine
Model No.	:	YX1715
Serial No.	:	YX01, YX02, YX03, AX01, AX02, AX03, BX01, BX02, BX03, CX01, CX02, CX03, DX01, DX02, DX03, EX01, EX02, EX03, FX01, FX02, FX03, GX01, GX02, GX03, HX01, HX02, HX03, IX01, IX02, IX03, YX01, YX02, YX03, JX01, JX02, JX03, KX01, KX02, KX03, LX01, LX02, LX03, MX01, MX02, MX03, NX01, NX02, NX03, OX01, OX02, OX03, PX01, PX02, PX03, QX01, QX02, QX03, RX01, RX02, RX03
Brand Name	:	N/A
Power Supply	:	DC 5V, 2A
<p>Remark: All above models are identical in schematic, structure and critical components except for only different appearance; therefore, EMC testing was performed with YX1715 only.</p>		

1.3. Block Diagram Showing the Configuration of System Tested



1.4. Description of Support Units

The EUT has been tested as an independent unit.

1.5. Performance Criterion

Criterion A: The equipment shall continue to operate as intended without operator intervention. No degradation of performance or loss of function is allowed below a performance level specified by the manufacturer when the equipment is used as intended.

Criterion B: After the test, the equipment shall continue to operate as intended without operator intervention. No degradation of performance or loss of function is allowed, after the application of the phenomena below a performance level specified by the manufacturer, when the equipment is used as intended.

Criterion C: Loss of function is allowed, provided the function is self-recoverable, or can be restored by the operation of the controls by the user in accordance with the manufacturer's instructions.

1.6. Classification of Apparatus

Category I: Apparatus containing no electronic control circuitry.

Category II: Transformer toys, dual supply toys, mains powered motor operated appliances, tools, heating appliances and similar electric apparatus (for example-UV radiators, IR radiators and microwave ovens) containing electronic control circuitry with no internal clock frequency or oscillator frequency higher than 15MHz.

Category III: Battery powered apparatus (with built-in batteries or external batteries), which in normal use is not connected to the mains, containing an electronic control circuitry with no internal clock frequency or oscillator frequency higher than 15MHz.

This category includes apparatus provided with rechargeable batteries which can be charged by connecting the apparatus to the mains power. However, this apparatus shall also be tested as an apparatus in category III while it is connected to the mains network.

Category IV: All other apparatus covered by the scope of this standard.

1.7. Test Facility

The testing report were performed by the Shenzhen LH Testing Technology Co., Ltd., in their facilities located at 106 and 107, building B15, Yintian Industrial Zone, Yantian community, Xixiang street, Bao'an District, Shenzhen.

2. Test Results Summary

EMISSION		
Description of test items	Standards	Results
Conducted disturbance at mains terminals	EN IEC 55014-1: 2021	Pass
Disturbance Power	EN IEC 55014-1: 2021	N/A
Click measurement	EN IEC 55014-1: 2021	N/A
Radiated disturbance	EN IEC 55014-1: 2021	Pass
Harmonic current emissions	EN IEC 61000-3-2: 2019/A1: 2021	N/A
Voltage fluctuation and flicker	EN 61000-3-3:2013+A2:2021	N/A
IMMUNITY		
Description of test items	Basic Standards	Results
Electrostatic Discharge (ESD)	EN 61000-4-2: 2009	Pass
Radio-frequency, Continuous Radiated Disturbance	EN IEC 61000-4-3:2020	Pass
EFT/B Immunity	EN 61000-4-4: 2012	N/A
Surge Immunity	EN 61000-4-5: 2014/A1:2017	N/A
Conducted RF Immunity	EN 61000-4-6: 2014	N/A
Voltage dips, 40% reduction	EN IEC 61000-4-11:2020	N/A
Voltage dips, 70% reduction		
Voltage interruptions		
Note: N/A is an abbreviation for Not Applicable.		

3. Test Equipment Used

3.1. Test Equipment Used to Measure Conducted Emission					
No.	Equipment	Manufacturer	Model No.	Last Cal.	Cal. Interval
LH-EMC001	EMI Test Receiver	Rohde & Schwarz	ESCS30	Dec. 29, 2022	1 Year
LH-EMC002	AMN	Rohde & Schwarz	ENV216	Dec. 29, 2022	1 Year
LH-EMC003	AMN	SCHWARZBECK	NNBL 8226	Dec. 29, 2022	1 Year
3.2. Test Equipment Used to Measure Disturbance Power					
No.	Equipment	Manufacturer	Model No.	Last Cal.	Cal. Interval
LH-EMC001	EMI Test Receiver	Rohde & Schwarz	ESCS30	Dec. 29, 2022	1 Year
LH-EMC028	Power Clamp	Luthi	MDS-21	Dec. 29, 2022	1 Year
3.3. Test Equipment Used to Measure Radiated Emission					
No.	Equipment	Manufacturer	Model No.	Last Cal.	Cal. Interval
LH-EMC004	EMI Test Receiver	Rohde & Schwarz	ESI26	Dec. 29, 2022	1 Year
LH-EMC005	Bilog Antenna	SCHWARZBECK	VULB9163	Dec. 29, 2022	1 Year
LH-EMC006	Positioning Controller	C&C	CC-C-1F	N/A	N/A
3.4. Test Equipment Used to Measure Harmonic Current/ Voltage Fluctuation and Flicker					
No.	Equipment	Manufacturer	Model No.	Last Cal.	Cal. Interval
LH-EMC007	Harmonic Flicker Test System	CI	5001ix-CTS-40	Dec. 29, 2022	1 Year
3.5. Test Equipment Used to Measure Electrostatic Discharge Immunity					
No.	Equipment	Manufacturer	Model No.	Last Cal.	Cal. Interval
LH-EMC008	ESD Tester	TESEQ	NSG437	Dec. 29, 2022	1 Year
3.6. Test Equipment Used to Measure Conducted Immunity					
LH-EMC009	RF Generator	FRANKONIA	CIT-10/75	Dec. 29, 2022	1 Year
LH-EMC010	Attenuator	FRANKONIA	59-6-33	Dec. 29, 2022	1 Year
LH-EMC011	M-CDN	LUTHI	M2/M3	Dec. 29, 2022	1 Year
LH-EMC012	CDN	LUTHI	AF2	Dec. 29, 2022	1 Year
LH-EMC013	EM Injection Clamp	LUTHI	EM101	Dec. 29, 2022	1 Year

3.7. Test Equipment Used to Measure Radio Frequency Electromagnetic Fields Immunity

No.	Equipment	Manufacturer	Model No.	Last Cal.	Cal. Interval
LH-EMC014	Signal Generator	Rohde & Schwarz	SMT03	Dec. 29, 2022	1 Year
LH-EMC015	Power Meter	Rohde & Schwarz	NRVD	Dec. 29, 2022	1 Year
LH-EMC016	Voltage Probe	Rohde & Schwarz	URV5-Z2	Dec. 29, 2022	1 Year
LH-EMC017	Voltage Probe	Rohde & Schwarz	URV5-Z2	Dec. 29, 2022	1 Year
LH-EMC018	Power Amplifier	AR	150W1000	Dec. 29, 2022	1 Year
LH-EMC019	Bilog Antenna	Chase	CBL6111C	Dec. 29, 2022	1 Year

3.8. Test Equipment Used to Measure Electrical Fast Transient/Burst Immunity

No.	Equipment	Manufacturer	Model No.	Last Cal.	Cal. Interval
LH-EMC020	Simulator	EMTEST	UCS500N5	Dec. 29, 2022	1 Year
LH-EMC021	Auto-transformer	EMTEST	V4780S2	Dec. 29, 2022	1 Year

3.9. Test Equipment Used to Measure Surge Immunity

No.	Equipment	Manufacturer	Model No.	Last Cal.	Cal. Interval
LH-EMC022	Simulator	EMTEST	UCS500N5	Dec. 29, 2022	1 Year
LH-EMC023	Coupling Clamp	EMTEST	HFK	Dec. 29, 2022	1 Year

3.10. Test Equipment Used to Measure Voltage Dips and Interruptions Immunity

No.	Equipment	Manufacturer	Model No.	Last Cal.	Cal. Interval
LH-EMC022	Simulator	EMTEST	UCS500N5	Dec. 29, 2022	1 Year
LH-EMC023	Coupling Clamp	EMTEST	HFK	Dec. 29, 2022	1 Year

4. Conducted Emission Test

4.1. Test Standard and Limit

4.1.1. Test Standard

EN IEC 55014-1: 2021.

4.1.2. Test Limit

Conducted Disturbance Test Limit

Frequency	Maximum RF Line Voltage (dB μ V)	
	Quasi-peak Level	Average Level
150kHz~350kHz	66 ~ 56*	56 ~ 46 *
350kHz~5MHz	56	46
5MHz~30MHz	60	50

Remark: "*" Decreasing linearly with logarithm of the frequency

4.2. Test Setup

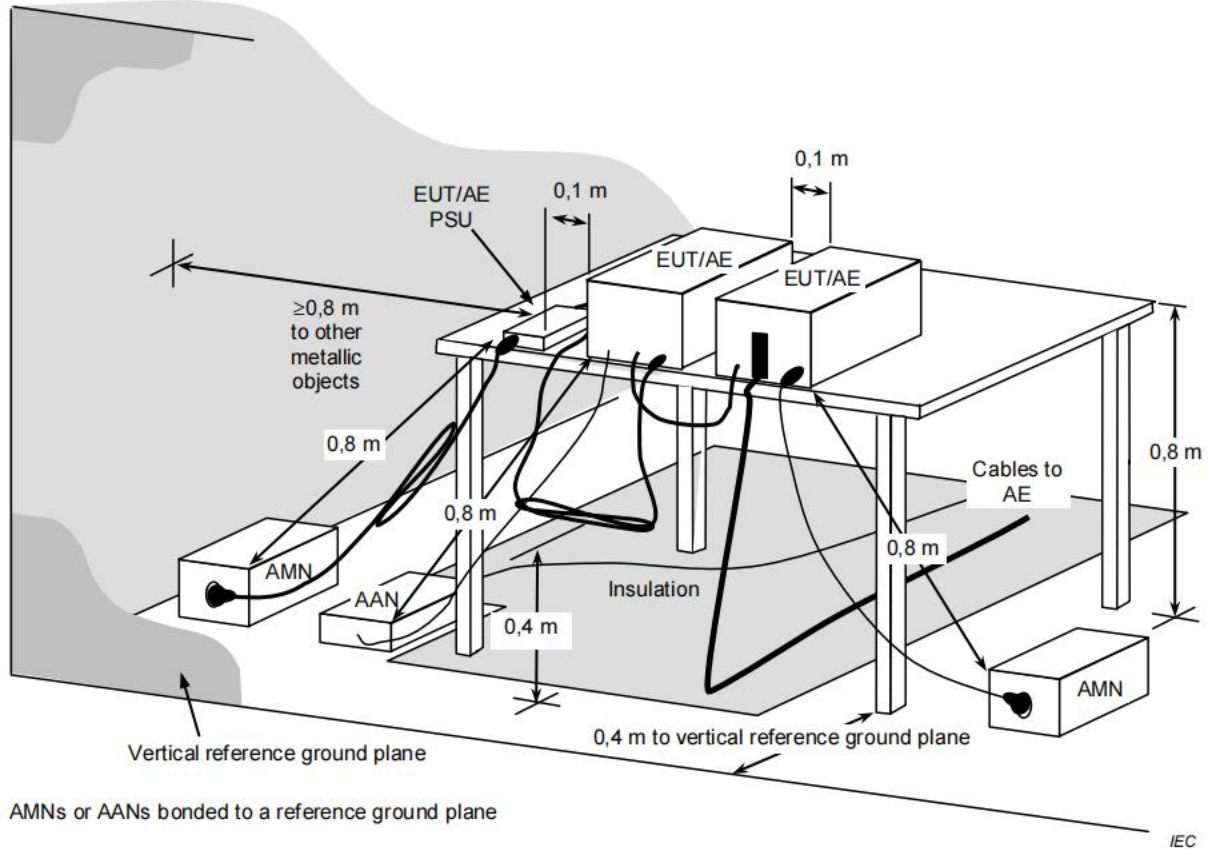

4.3. Test Procedure

The EUT was placed 0.8 meters from the horizontal ground plane with EUT being

connected to the power mains through a line impedance stabilization network (LISN). All other support equipments powered from additional LISN(s). The LISN provide 50 Ohm/50uH of coupling impedance for the measuring instrument.

Interconnecting cables that hang closer than 40 cm to the ground plane shall be folded back and forth in the center forming a bundle 30 to 40 cm long.

I/O cables that are not connected to a peripheral shall be bundled in the center. The end of the cable may be terminated, if required, using the correct terminating impedance. The overall length shall not exceed 1 m.

LISN at least 80 cm from nearest part of EUT chassis.

The bandwidth of EMI test receiver is set at 9kHz, and the test frequency band is from 0.15MHz to 30MHz.

4.4. Test Condition

Temperature	:	25 °C
Relative Humidity	:	48 %
Pressure	:	1010 hPa
Test Power	:	DC 5V

4.5. Test Data

Please refer to the following pages.

Operating Condition: Normal

Test Specification: L

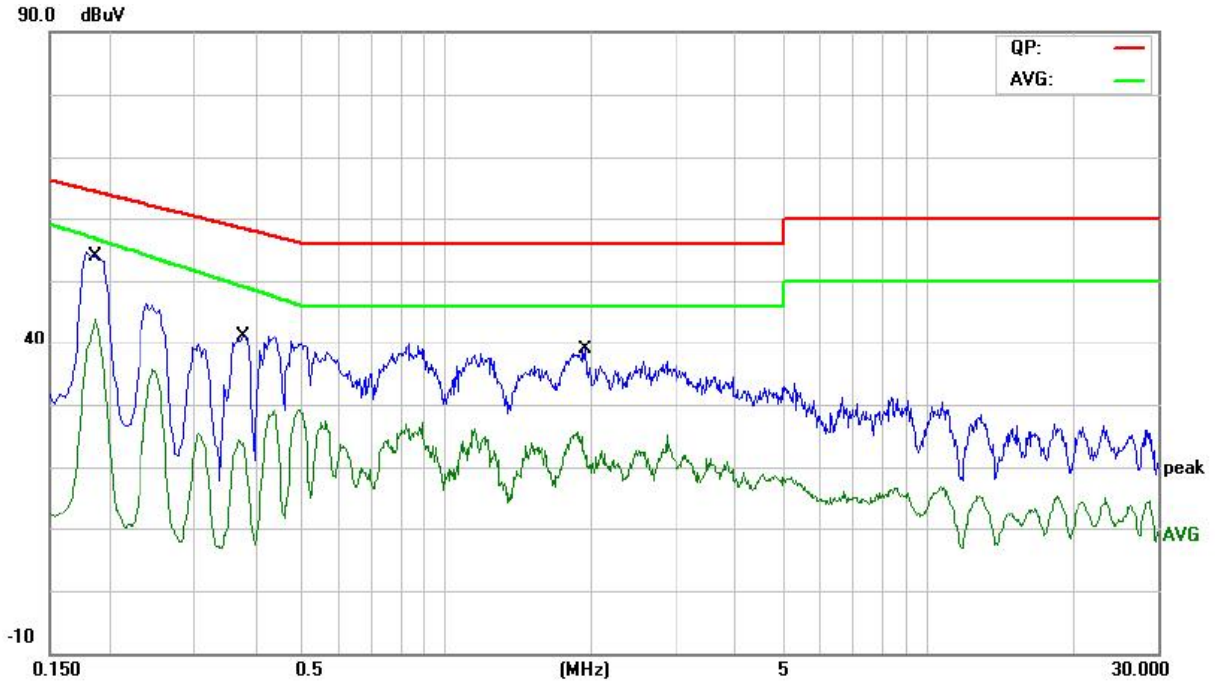

No.	Mk.	Freq. MHz	Reading Level dBuV	Correct Factor dB	Measure- ment dBuV	Limit dBuV	Over dB	Detector	Comment
1	*	0.1884	41.35	10.45	51.80	64.10	-12.30	QP	
2		0.1884	30.35	10.45	40.80	56.53	-15.73	AVG	
3		0.3780	26.27	9.65	35.92	58.32	-22.40	QP	
4		0.3780	13.27	9.65	22.92	49.02	-26.10	AVG	
5		1.9460	23.01	9.33	32.34	56.00	-23.66	QP	
6		1.9460	11.44	9.33	20.77	46.00	-25.23	AVG	

Operating Condition: Normal

Test Specification: N

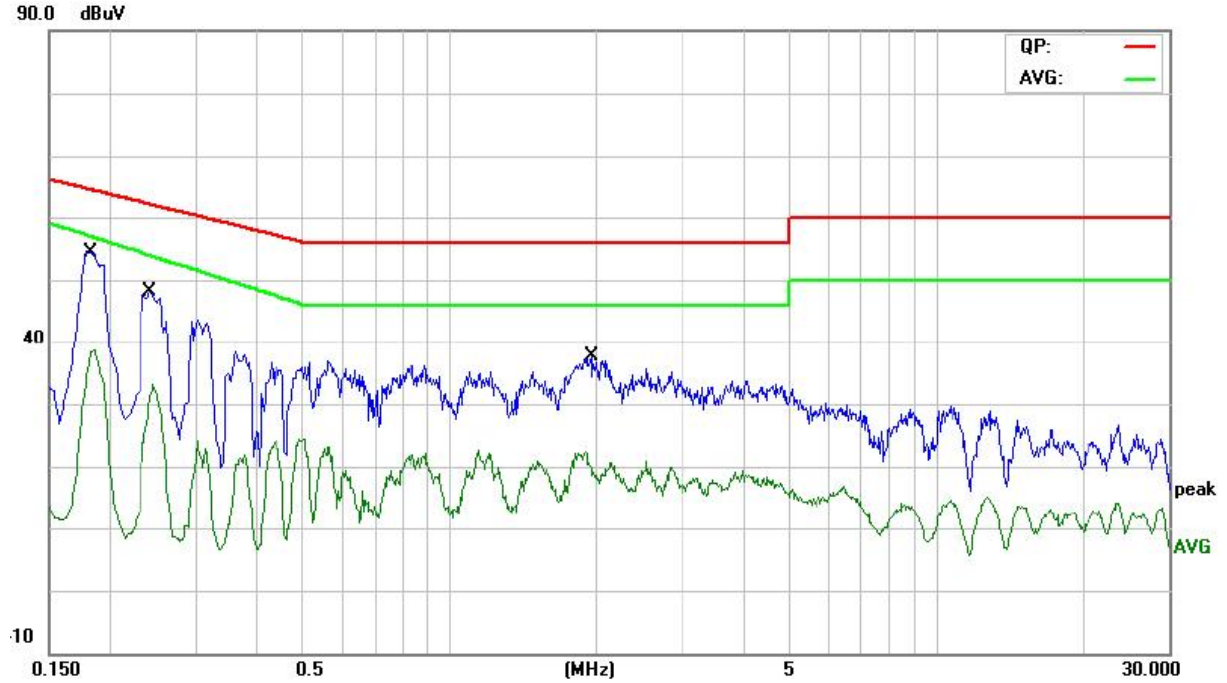

No.	Mk.	Freq.	Reading Level	Correct Factor	Measurement	Limit	Over	Detector	Comment
		MHz	dBuV	dB	dBuV	dBuV	dB		
1	*	0.1844	39.84	10.53	50.37	64.28	-13.91	QP	
2		0.1844	26.88	10.53	37.41	56.76	-19.35	AVG	
3		0.2420	32.93	10.04	42.97	62.02	-19.05	QP	
4		0.2420	19.95	10.04	29.99	53.83	-23.84	AVG	
5		1.9580	20.80	9.36	30.16	56.00	-25.84	QP	
6		1.9580	9.26	9.36	18.62	46.00	-27.38	AVG	

5. Radiated Emission Test

5.1. Test Standard and Limit

5.1.1. Test Standard

EN IEC 55014-1: 2021.

5.1.2. Test Limit

Radiated Disturbance Test Limit

Frequency	Limit (dB μ V/m)
	Quasi-peak Level
30MHz~230MHz	40
230MHz~1000MHz	47

Remark: 1. The lower limit shall apply at the transition frequency.
2. The test distance is 3m.

5.2. Test Setup

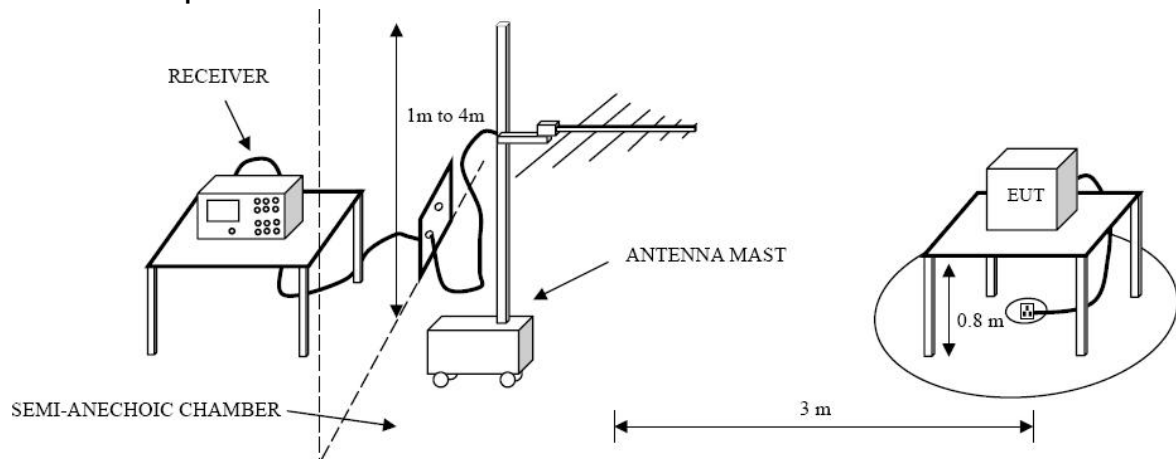

5.3. Test Procedure

The EUT was placed on the top of a rotating table 0.8 meters above the ground at a 3m. The table was rotated 360 degrees to determine the position of the highest radiation.

The height of the equipment or of the substitution antenna shall be 0.8 m; the height of the test antenna shall vary between 1 m to 4 m. Both horizontal and vertical polarizations of the antenna are set to make the measurement.

The initial step in collecting radiated emission data is a spectrum analyzer peak detector mode pre-scanning the measurement frequency range.

If the Peak Mode measured value compliance with and lower than Quasi Peak Mode Limit, the EUT shall be deemed to meet QP Limits and then no additional QP Mode measurement performed.

5.4. Test Condition

Temperature	:	23 °C
Relative Humidity	:	52 %
Pressure	:	1010 hPa
Test Power	:	DC 5V

5.5. Test Data

Please refer to the following pages.

Operating Condition: Normal
Test Specification: Horizontal

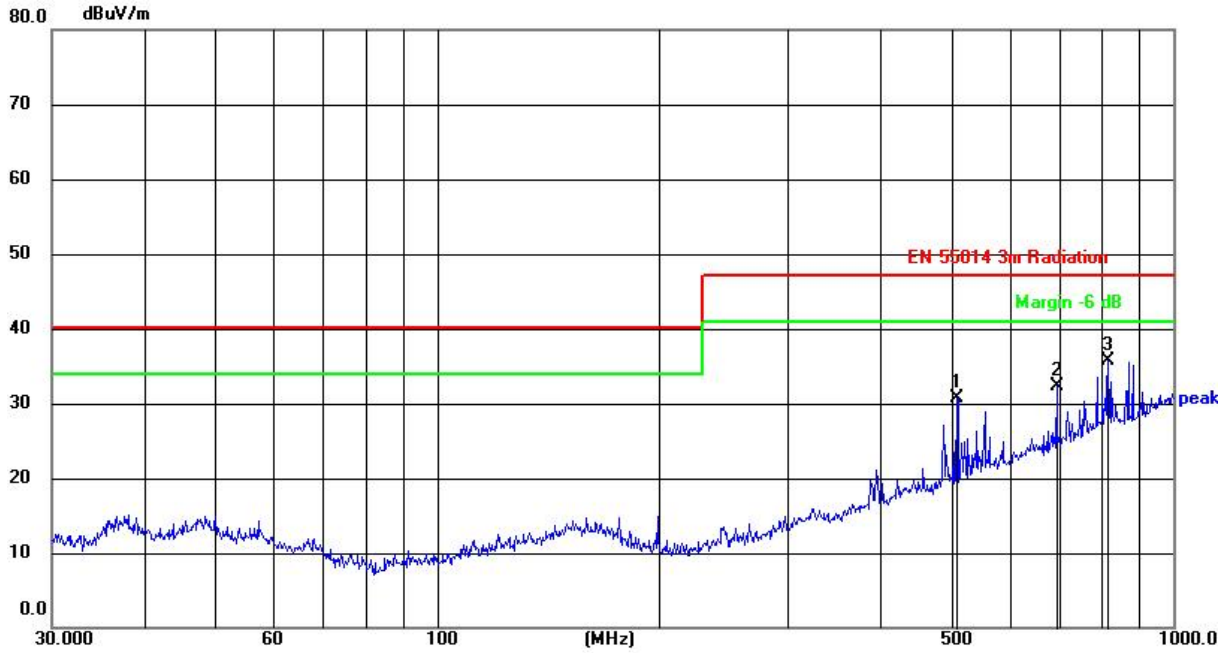

No.	Frequency (MHz)	Reading (dBuV)	Factor (dB/m)	Level (dBuV/m)	Limit (dBuV/m)	Margin (dB)	Detector	Height (cm)	Azimuth (deg.)	P/F	Remark
1	508.2582	44.70	-13.97	30.73	47.00	-16.27	peak				
2	694.4174	41.61	-9.32	32.29	47.00	-14.71	peak				
3	815.9678	42.09	-6.43	35.66	47.00	-11.34	peak				

Operating Condition: Normal
Test Specification: Vertical

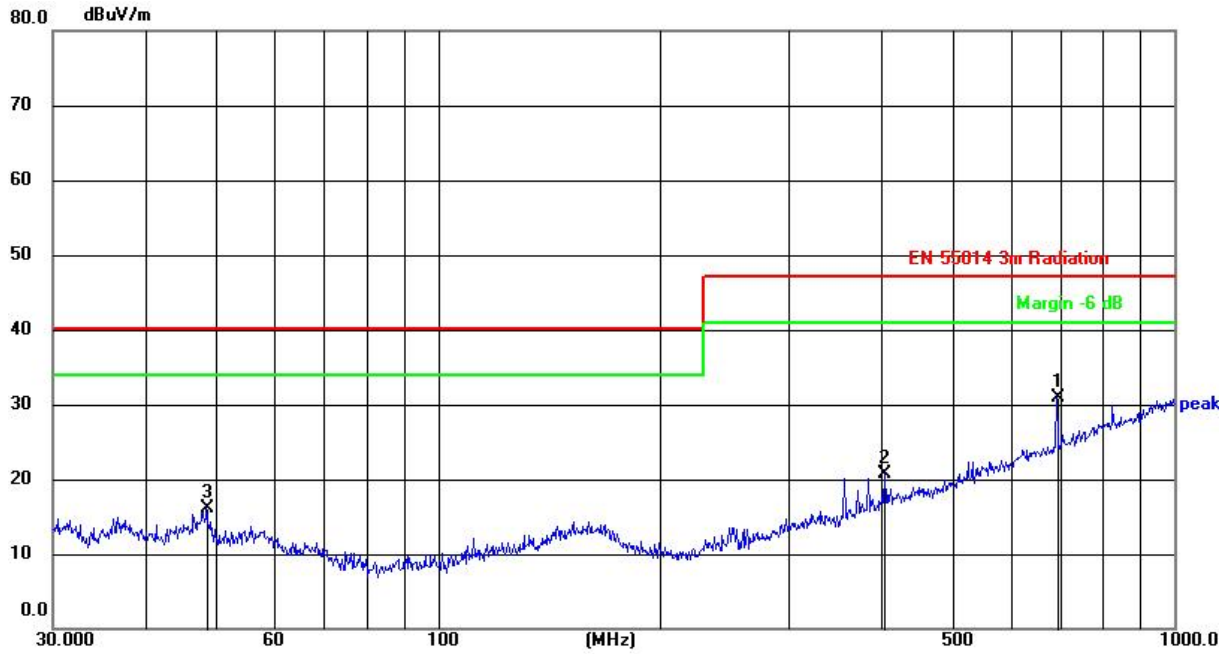

No.	Frequency (MHz)	Reading (dBuV)	Factor (dB/m)	Level (dBuV/m)	Limit (dBuV/m)	Margin (dB)	Detector	Height (cm)	Azimuth (deg.)	P/F	Remark
1	691.9867	40.28	-9.40	30.88	47.00	-16.12	peak				
2	404.6665	37.75	-17.10	20.65	47.00	-26.35	peak				
3	48.5016	37.83	-21.63	16.20	40.00	-23.80	peak				

6. Electrostatic Discharge Immunity Test

6.1. Test Requirements

6.1.1. Test Standard

EN IEC 55014-2: 2021 (EN 61000-4-2:2009)

6.1.2. Test Level

Level	Test Voltage Contact Discharge (KV)	Test Voltage Air Discharge (KV)
1.0	±2	±2
2.0	±4	±4
3.0	±6	±8
4.0	±8	±15
X	Special	Special

6.1.3. Performance criterion: B

6.2. Test Setup

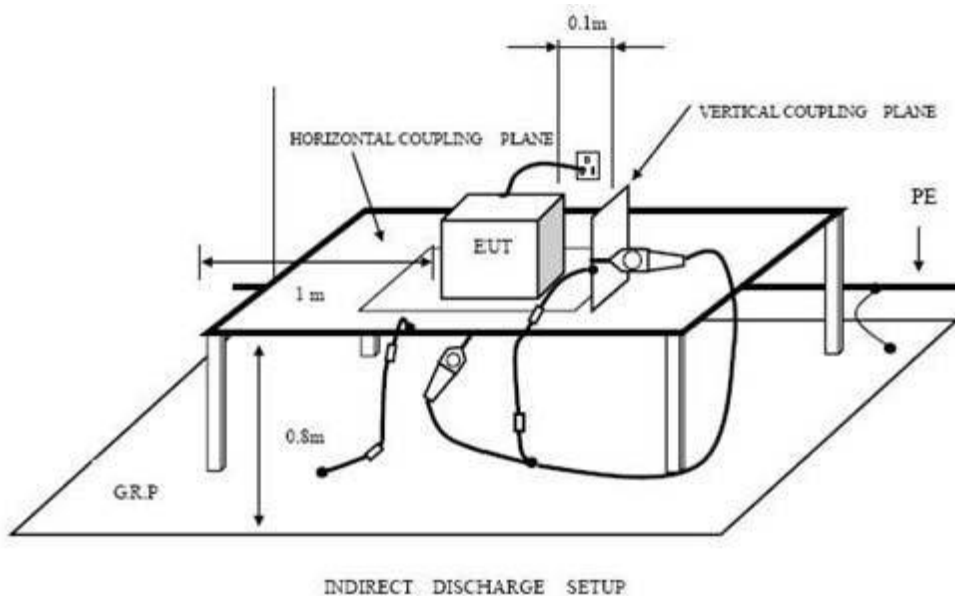

6.3. Test Procedure

6.3.1. Air Discharge:

This test is done on a non-conductive surface. The round discharge tip of the discharge electrode shall be approached as fast as possible to touch the EUT. After each discharge, the discharge electrode shall be removed from the EUT. The generator is then re-triggered for a new single discharge and repeated 10 times for each pre-selected test point. This procedure shall be repeated until all the air discharge completed.

6.3.2. Contact Discharge:

All the procedure shall be same as air discharge. Except that the tip of the discharge electrode shall touch the EUT before the discharge switch is operated.

6.3.3. Indirect discharge for horizontal coupling plane

At least 10 single discharges (in the most sensitive polarity) shall be applied at the front edge of each HCP opposite the center point of each unit (if applicable) of the EUT and 0.1m from the front of the EUT. The long axis of the discharge electrode shall be in the plane of the HCP and perpendicular to its front edge during the discharge.

6.3.4. Indirect discharge for vertical coupling plane

At least 10 single discharges (in the most sensitive polarity) shall be applied to the center of one vertical edge of the coupling plane. The coupling plane, of dimensions 0.5m X 0.5m, is placed parallel to, and positioned at a distance of 0.1m from the EUT. Discharges shall be applied to the coupling plane, with this plane in sufficient different positions that the four faces of the EUT are completely illuminated.

6.4. Test Data

Please refer to the following page.

Electrostatic Discharge Test Result

EUT : <u>Integrated machine</u>	M/N : <u>YX1715</u>	
Temperature : <u>22°C</u>	Humidity : <u>50%</u>	
Power supply : <u>DC 5V</u>	Test Mode : <u>Normal</u>	
Criterion: B		
Air Discharge: ±8kV Contact Discharge: ±4kV		
For each point positive 10 times and negative 10 times discharge.		
Location	Kind A-Air Discharge C-Contact Discharge	Result
Nonconductive Enclosure	A	PASS
Button	A	PASS
Conductive Enclosure	C	PASS
HCP	C	PASS
VCP of front	C	PASS
VCP of rear	C	PASS
VCP of left	C	PASS
VCP of right	C	PASS
Remark:		

7. Radiated Electromagnetic Field Immunity test

7.1. Test Requirements

7.1.1. Test Standard

EN IEC 55014-2: 2021 (EN IEC 61000-4-3:2020)

7.1.2. Test Level

Level	Field Strength V/m
1.0	1
2.0	3
3.0	10
X	Special

7.1.3. Performance criterion: A

7.2. Test Setup

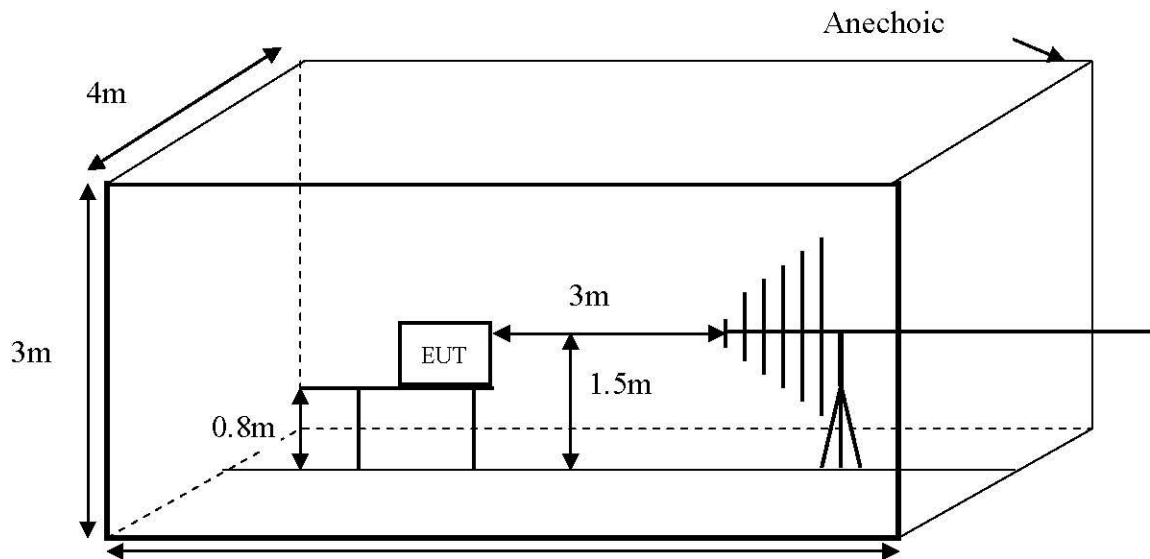

7.3. Test Procedure

The EUT are placed on a table, which is 0.8 meter high above the ground. The EUT is set 3 meters away from the transmitting antenna, which is mounted on an antenna tower. Both horizontal and vertical polarization of the antenna is set on test. Each of the four sides of the EUT must be faced this transmitting antenna and measured individually.

In order to judge the EUT performance, a camera is used to monitor its screen.

All the scanning conditions are as following:

Condition of Test	Remark
1. Fielded Strength	3V/m (Severity Level 2)
2. Radiated Signal	Modulated
3. Scanning Frequency	80-1000MHz
4. Sweep time of radiated	0.0015 Decade/s
5. Dwell Time	1 Sec.

7.4. Test Data

Please refer to the following page.

RF Field Strength Susceptibility Test Results

EUT	: <u>Integrated machine</u>	M/N	: <u>YX1715</u>	
Temperature	: <u>22°C</u>	Humidity	: <u>50%</u>	
Power supply	: <u>DC 5V</u>	Test Mode	: <u>Normal</u>	
Criterion: A				
Modulation: Unmodulated				
Pulse: AM 1KHz 80%				
	Frequency Range 1		Frequency Range 2	
	80~1000MHz		/	
	Horizontal	Vertical	Horizontal	Vertical
Front	PASS	PASS	/	/
Right	PASS	PASS	/	/
Rear	PASS	PASS	/	/
Left	PASS	PASS	/	/

8. Photographs - Constructional Details

Photo 1 Appearance of EUT



Photo 2 Appearance of EUT



Photo 3 inside of EUT

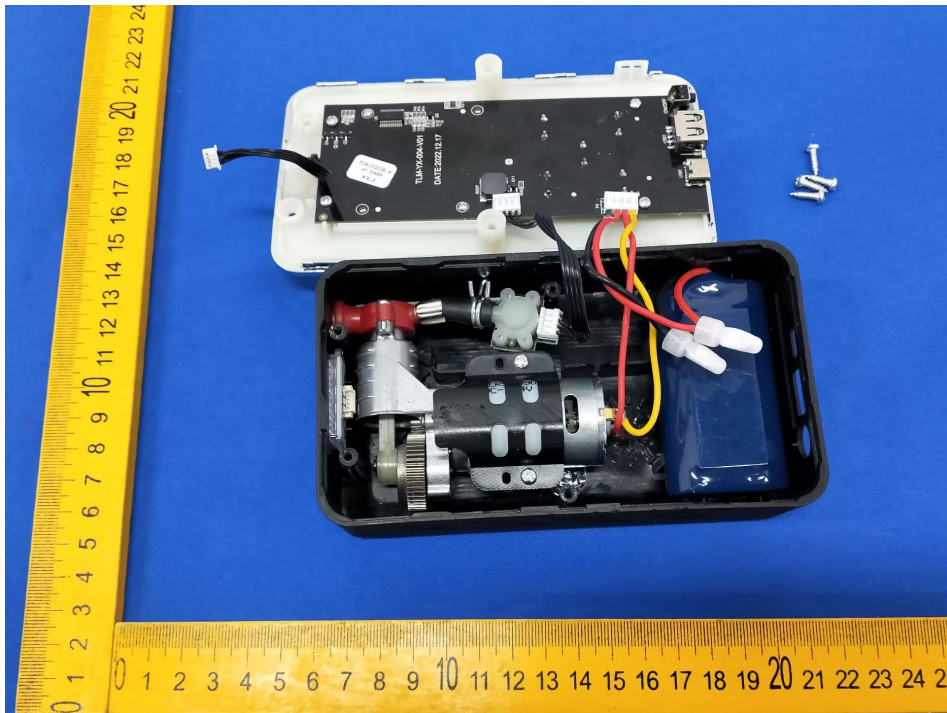

Photo 4 Appearance of PCB

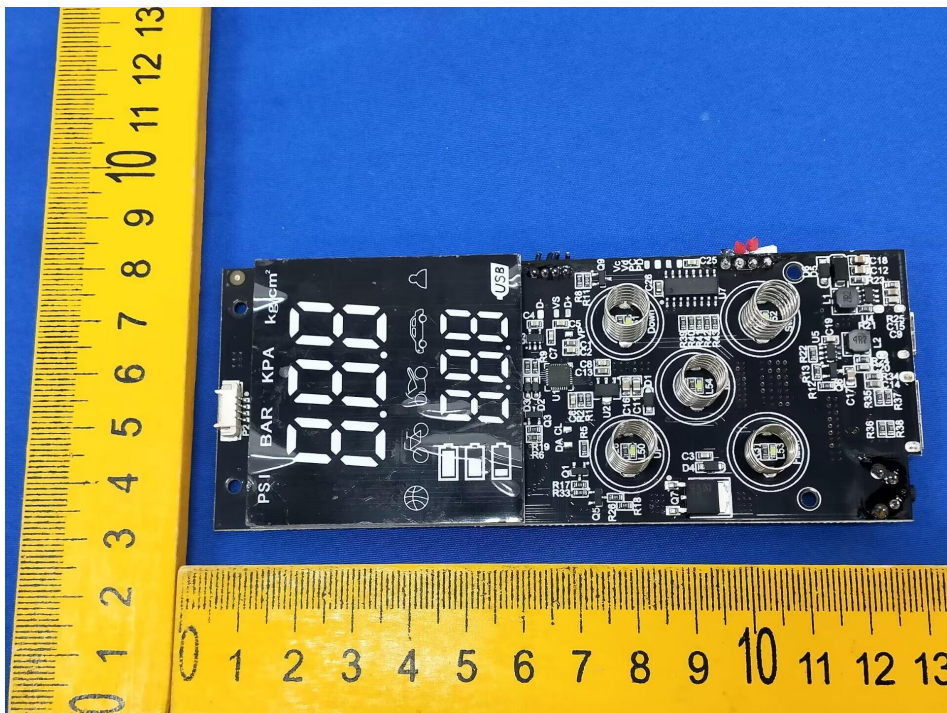

Photo 5 Appearance of PCB

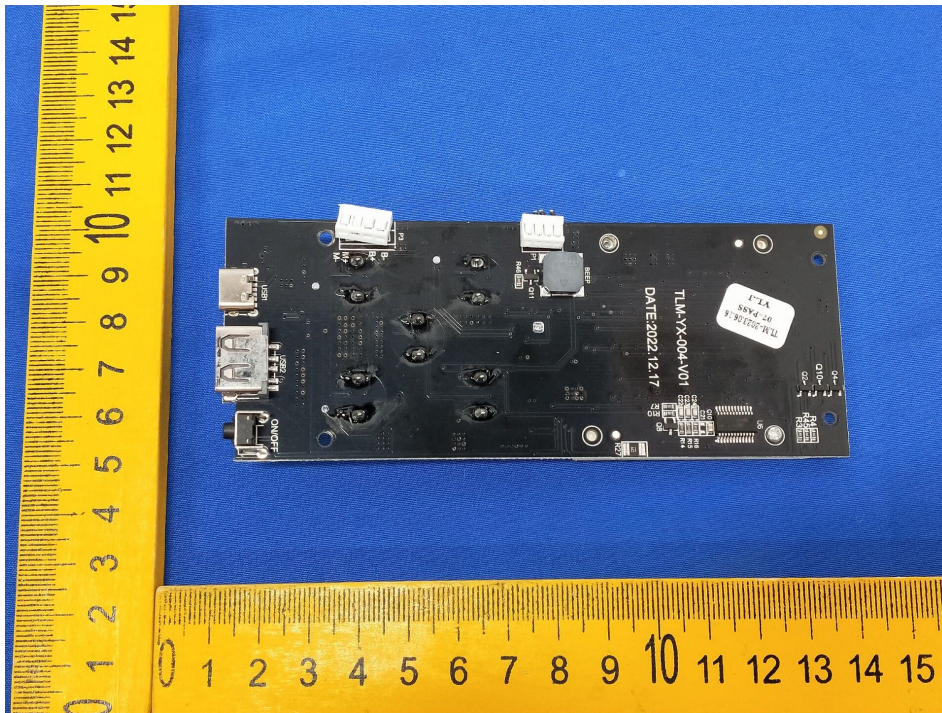
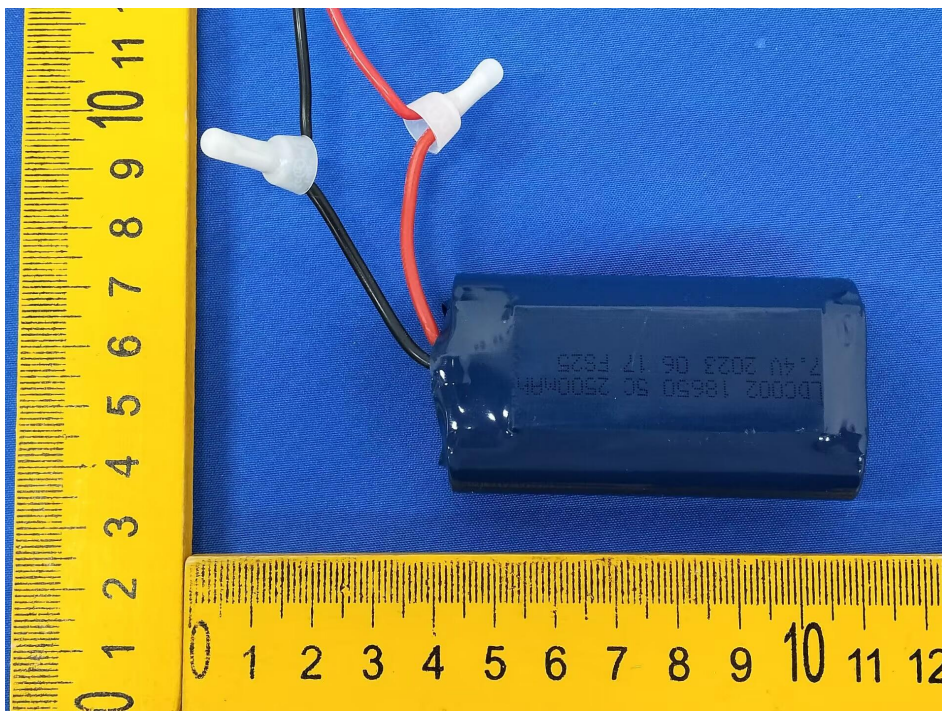
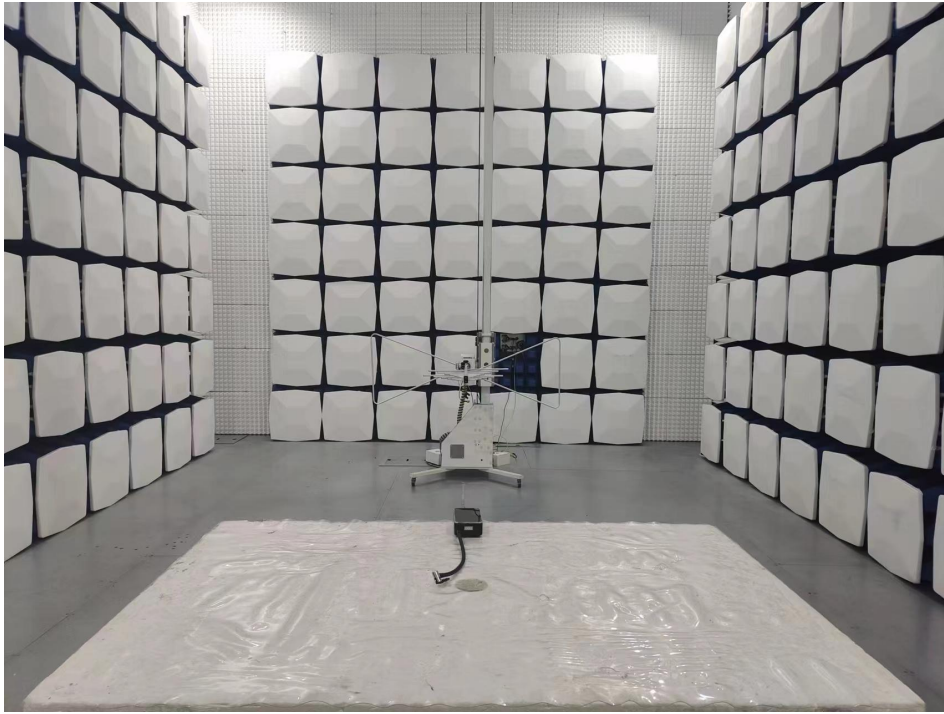

Photo 6 Appearance of Battery



Test photo



END OF REPORT