



# RADIO TEST REPORT

**Applicant:** Shenzhen Guard Dragon Electronics Co., Ltd.  
**Address:** 2F-D205, Xintian Bairuida Building Wanke City Community, Sakantian Street Longgang District, Shenzhen City, China  
**Manufacturer:** Shenzhen Guard Dragon Electronics Co., Ltd.  
**Address:** 2F-D205, Xintian Bairuida Building Wanke City Community, Sakantian Street Longgang District, Shenzhen City, China  
**EUT:** Vehicle player  
**Trade Mark:** SWM  
FS02W  
SWM-8807, 1008, M12, K-701, 9602-S, 9603-S, T100-S, 9606, 9606-S, 9901, 9901-S, B5300, B5300A, B5310, B5303, FS740, FS750, FS760, FS770, FS780, 9601C-S, 617, D3105, D3108, D3111, D3113, D3112, D3114, D3100, D3101, D3103, D3104, D3102, D3106, D3107, D3109, D3110, 1792, S3700, 1790, T100C-S, F9070, F9093C, F9090C, F9101C, FS06W, FS07W, SWM, 160C, F170C, B500W, B600W, FS06C, 9083C, SWM, 151C, FS03W, SWM, 5015, SWM, 5016, SWM, 5017, A8, F760, F770, F780, 9602G-S, 9603G-S, T100G-S, 9701-S, 9702-S, 9210S-J, 9090-J, 9101-J, 9210, 9606A, 9901C, D9603C, 9606C, 3012, F7018, 9708, 7764H, S-Toyota, S-9071, S-Fox-Black, S-Fox-Silver, 170C, S-9019C, 7002, 7003, 6008, 6006, S-9019C, 6200C, D3156, D3162, B5304, B5301, B5302, B5305, 1791, D5400  
**Model Number:**  
**Date of Receipt:** Mar. 13, 2023  
**Test Date:** Mar. 13, 2023 - Mar. 24, 2023  
**Date of Report:** Mar. 24, 2023  
**Prepared By:** Shenzhen DL Testing Technology Co., Ltd.  
**Address:** 101-201, Building C, Shuanghuan, No.8, Baoqing Road, Baolong Industrial Zone, Baolong Street, Longgang District, Shenzhen, Guangdong, China  
**Applicable Standards:** ETSI EN 300 328 V2.2.2 (2019-07)  
**Test Result:** Pass  
**Report Number:** DL-20230324026-3E

**Prepared (Engineer):** Alisa Song

**Reviewer (Supervisor):** Jack Bu

**Approved (Manager):** Jade Yang



*This test report is based on a single evaluation of one sample of above mentioned products. It is not permitted to be duplicated in extracts without written approval of Shenzhen DL Testing Technology Co., Ltd.*



**TABLE OF CONTENT**

Test Report Declaration	Page
<b>1. VERSION .....</b>	<b>3</b>
<b>2. TEST SUMMARY .....</b>	<b>3</b>
<b>3. GENERAL INFORMATION .....</b>	<b>4</b>
<b>4. TEST INSTRUMENT USED .....</b>	<b>12</b>
<b>5. RF OUTPUT POWER .....</b>	<b>13</b>
<b>6. DUTY CYCLE, TX-SEQUENCE, TX-GAP .....</b>	<b>15</b>
<b>7. ACCUMULATED TRANSMIT TIME, FREQUENCY OCCUPATION AND HOPPING SEQUENCE ....</b>	<b>16</b>
<b>8. HOPPING FREQUENCY SEPARATION .....</b>	<b>18</b>
<b>9. ADAPTIVITY .....</b>	<b>20</b>
<b>10. OCCUPIED CHANNEL BANDWIDTH .....</b>	<b>22</b>
<b>11. TRANSMITTER UNWANTED EMISSIONS IN THE OUT-OF-BAND DOMAIN .....</b>	<b>23</b>
<b>12. TRANSMITTER UNWANTED EMISSIONS IN THE SPURIOUS DOMAIN .....</b>	<b>26</b>
<b>13. RECEIVER SPURIOUS EMISSIONS .....</b>	<b>30</b>
<b>14. RECEIVER BLOCKING .....</b>	<b>34</b>
<b>15. GEO-LOCATION CAPABILITY .....</b>	<b>37</b>
<b>16. SETUP PHOTOGRAPHS .....</b>	<b>38</b>
<b>17. EUT PHOTOGRAPHS .....</b>	<b>38</b>



## 1. VERSION

Version No.	Date	Description
00	Mar. 24, 2023	Original

## 2. TEST SUMMARY

No	Test Item	Clause No	Result
<b>Transmitter Parameters</b>			
1	RF output power	4.3.1.2	PASS
2	Duty Cycle, Tx-sequence, Tx-gap	4.3.1.3	N/A
3	Accumulated Transmit Time, Frequency Occupation and Hopping Sequence	4.3.1.4	PASS
4	Hopping Frequency Separation	4.3.1.5	PASS
5	Medium Utilization (MU) factor	4.3.1.6	N/A
6	Adaptivity (Adaptive FHSS)	4.3.1.7	N/A
7	Occupied Channel Bandwidth	4.3.2.8	PASS
8	Transmitter unwanted emissions in the out-of-band domain	4.3.2.9	PASS
9	Transmitter unwanted emissions in the spurious domain	4.3.2.10	PASS
<b>Receiver Parameters</b>			
9	Receiver spurious emissions	4.3.2.11	PASS
10	Receiver Blocking	4.3.2.12	PASS
11	Geo-location capability	4.3.2.13	N/A
Note: (1) "N/A" denotes test is not applicable in this Test Report (2) Test Facility: Shenzhen DL Testing Technology Co., Ltd. Address: 101-201, Building C, Shuanghuan, No.8, Baoqing Road, Baolong Industrial Zone, Baolong Street, Longgang District, Shenzhen, Guangdong, China			



### 3. GENERAL INFORMATION

#### 3.1 Description of Device (EUT)

EUT:	Vehicle player
Trade Mark:	SWM FS02W SWM-8807, 1008, M12, K-701, 9602-S, 9603-S, T100-S, 9606, 9606-S, 9901, 9901-S, B5300, B5300A, B5310, B5303, FS740, FS750, FS760, FS770, FS780, 9601C-S, 617, D3105, D3108, D3111, D3113, D3112, D3114, D3100, D3101, D3103, D3104, D3102, D3106, D3107, D3109, D3110, 1792, S3700, 1790, T100C-S, F9070, F9093C, F9090C, F9101C, FS06W, FS07W, SWM, 160C, F170C, B500W, B600W, FS06C, 9083C, SWM, 151C, FS03W, SWM, 5015, SWM, 5016, SWM, 5017, A8, F760, F770, F780, 9602G-S, 9603G-S, T100G-S, 9701-S, 9702-S, 9210S-J, 9090-J, 9101-J, 9210, 9606A, 9901C, D9603C, 9606C, 3012, F7018, 9708, 7764H, S-Toyota, S-9071, S-Fox-Black, S-Fox-Silver, 170C, S-9019C, 7002, 7003, 6008, 6006, S-9019C, 6200C, D3156, D3162, B5304, B5301, B5302, B5305, 1791, D5400
Model Number:	
Test Model:	FS02W
Model difference:	The product's different for model number and appearance color.
Power Supply:	DC 12V
Receiver Category:	3
Operation Frequency:	2402~2480 MHz
Modulation Type:	GFSK, PI/4 DQPSK, 8DPSK
Number of Channel:	79
Bit Rate of Transmitter:	1Mbps
Antenna Type:	Internal Antenna
Antenna Gain:	1.08dBi
Hardware Version:	1.0
Software Version:	1.0
Firmware:	---

Note1: For a more detailed features description, please refer to the manufacturer's specifications or the User's Manual.

Channel List							
Channel	Frequency (MHz)	Channel	Frequency (MHz)	Channel	Frequency (MHz)	Channel	Frequency (MHz)
00	2402	21	2423	40	2442	61	2463
01	2403	22	2424	41	2443	62	2464
02	2404	23	2425	42	2444	63	2465
~	~	~	~	~	~	~	~
18	2420	37	2439	58	2460	76	2478
19	2421	38	2440	59	2461	77	2479
20	2422	39	2441	60	2462	78	2480



**ANNEX E.2**

**a) The type of wideband data transmission equipment:**

- FHSS
- non-FHSS

**b) In case of FHSS:**

- In case of non-Adaptive FHSS equipment:  
The number of Hopping Frequencies:
- In case of Adaptive FHSS equipment:  
The maximum number of Hopping Frequencies: 79  
The minimum number of Hopping Frequencies: 79
- The (average) dwell time:

**c) Adaptive / non-adaptive equipment:**

- non-adaptive Equipment
- adaptive Equipment without the possibility to switch to a non-adaptive mode
- adaptive Equipment which can also operate in a non-adaptive mode

**d) In case of adaptive equipment:**

- The Channel Occupancy Time implemented by the equipment: ms
- The equipment has implemented an LBT mechanism
- In case of non-FHSS equipment:
  - The equipment is Frame Based equipment
  - The equipment is Load Based equipment
  - The equipment can switch dynamically between Frame Based and Load Based equipment
- The CCA time implemented by the equipment: .....  $\mu$ s
- The equipment has implemented a DAA mechanism
- The equipment can operate in more than one adaptive mode

**e) In case of non-adaptive Equipment:**

- The maximum RF Output Power (e.i.r.p.): -1.01 dBm
- The maximum (corresponding) Duty Cycle: ..... %
- Equipment with dynamic behaviour, that behaviour is described here. (e.g. the different combinations of duty cycle and corresponding power levels to be declared):

**f) The worst case operational mode for each of the following tests:**

- RF Output Power  
GFSK
- Power Spectral Density  
GFSK
- Duty cycle, Tx-Sequence, Tx-gap  
GFSK
- Accumulated Transmit time, Frequency Occupation & Hopping Sequence (only for FHSS equipment)  
.....
- Hopping Frequency Separation (only for FHSS equipment)  
.....
- Medium Utilisation  
.....



- Adaptivity & Receiver Blocking  
.....
- Nominal Channel Bandwidth  
1MHz
- Transmitter unwanted emissions in the OOB domain  
GFSK
- Transmitter unwanted emissions in the spurious domain  
GFSK
- Receiver spurious emissions  
GFSK

**g) The different transmit operating modes (tick all that apply):**

- Operating mode 1: Single Antenna Equipment
- Equipment with only one antenna
- Equipment with two diversity antennas but only one antenna active at any moment in time
- Smart Antenna Systems with two or more antennas, but operating in a (legacy) mode where only one antenna is used (e.g. IEEE 802.11™ legacy mode in smart antenna systems)
- Operating mode 2: Smart Antenna Systems - Multiple Antennas without beam forming
- Single spatial stream/Standard throughput/(e.g. IEEE 802.11™ legacy mode)
- High Throughput (> 1 spatial stream) using Nominal Channel Bandwidth 1
- High Throughput (> 1 spatial stream) using Nominal Channel Bandwidth 2

NOTE1: Add more lines if more channel bandwidths are supported.

- Operating mode 3: Smart Antenna Systems - Multiple Antennas with beam forming
- Single spatial stream/Standard throughput (e.g. IEEE 802.11™ legacy mode)
- High Throughput (> 1 spatial stream) using Nominal Channel Bandwidth 1
- High Throughput (> 1 spatial stream) using Nominal Channel Bandwidth 2

NOTE2: Add more lines if more channel bandwidths are supported.

**h) In case of Smart Antenna Systems:**

- The number of Receive chains: .....
- The number of Transmit chains: .....
- symmetrical power distribution
- asymmetrical power distribution

In case of beam forming, the maximum (additional) beam forming gain: ..... dB

NOTE: The additional beam forming gain does not include the basic gain of a single antenna.

**i) Operating Frequency Range(s) of the equipment:**

- Operating Frequency Range 1: 2402 MHz to 2480 MHz
- Operating Frequency Range 2: .... MHz to .... MHz

NOTE: Add more lines if more Frequency Ranges are supported.

**j) Occupied Channel Bandwidth(s):**

- Nominal Channel Bandwidth 1: 0.852MHz
- Nominal Channel Bandwidth 2: 1.165MHz

NOTE: Add more lines if more channel bandwidths are supported.

**k) Type of Equipment (stand-alone, combined, plug-in radio device, etc.):**

- Stand-alone
- Combined Equipment



- Plug-in radio device
- Other .....

**l) The normal and the extreme operating conditions that apply to the equipment:**

**Normal operating conditions (if applicable):**

Operating temperature: 25° C  
 Other (please specify if applicable): .....

**Extreme operating conditions:**

Operating temperature range: Minimum: -20 °C    Maximum 55°C  
 Other (please specify if applicable):    Minimum: ..... Maximum .....

- Details provided are for the:  stand-alone equipment  
 combined (or host) equipment  
 test jig

**m) The intended combination(s) of the radio equipment power settings and one or more antenna assemblies and their corresponding e.i.r.p. levels:**

- Antenna Type
  - Internal Antenna (information to be provided in case of conducted measurements)
    - Antenna Gain: 1.08 dBi
    - If applicable, additional beamforming gain (excluding basic antenna gain): ..... dB
  - Temporary RF connector provided
  - No temporary RF connector provided
  - Dedicated Antennas (equipment with antenna connector)
  - Single power level with corresponding antenna(s)
  - Multiple power settings and corresponding antenna(s)
    - Number of different Power Levels: .....
    - Power Level 1: ..... dBm
    - Power Level 2: ..... dBm
    - Power Level 3: ..... dBm
- NOTE 1: Add more lines in case the equipment has more power levels.
- NOTE 2: These power levels are conducted power levels (at antenna connector).
- For each of the Power Levels, provide the intended antenna assemblies, their corresponding gains (G) and the resulting e.i.r.p. levels also taking into account the beamforming gain (Y) if applicable

**Power Level 1: -1.01dBm**

Number of antenna assemblies provided for this power level:

Assembly #	Gain (dBi)	e.i.r.p. (dBm)	Part number or model name
1	1.08	-1.01	
2			
3			
4			

NOTE 3: Add more rows in case more antenna assemblies are supported for this power level.



Power Level 2: ..... dBm

Number of antenna assemblies provided for this power level:

Assembly #	Gain (dBi)	e.i.r.p. (dBm)	Part number or model name
1			
2			
3			
4			

NOTE 4: Add more rows in case more antenna assemblies are supported for this power level.

Power Level 3: ..... dBm

Number of antenna assemblies provided for this power level:

Assembly #	Gain (dBi)	e.i.r.p. (dBm)	Part number or model name
1			
2			
3			
4			

NOTE 5: Add more rows in case more antenna assemblies are supported for this power level.

**n) The nominal voltages of the stand-alone radio equipment or the nominal voltages of the combined equipment or test jig in case of plug-in devices:**

- Details provided are for the:  stand-alone equipment  
 combined equipment  
 test jig

Supply Voltage  AC mains      State AC voltage    V  
 DC State      DC voltage : 12V

In case of DC, indicate the type of power source

- Internal Power Supply  
 External Power Supply or AC/DC adapter  
 Battery: 12V  
 Other:

**o) Describe the test modes available which can facilitate testing:**

The EUT can be into the Engineer mode for testing.

**p) The equipment type (e.g. Bluetooth®, IEEE 802.11™, IEEE 802.15.4™, proprietary, etc.):**

Bluetooth

**q) If applicable, the statistical analysis referred to in clause 5.4.1 q)**

(to be provided as separate attachment)

**r) If applicable, the statistical analysis referred to in clause 5.4.1 r)**

(to be provided as separate attachment)

**s) Geo-location capability supported by the equipment:**

- Yes  
 The geographical location determined by the equipment as defined in clause 4.3.1.13.2 or clause 4.3.2.12.2 is not accessible to the user  
 No



**ANNEX E.3**

From all combinations of conducted power settings and intended antenna assembly(ies) specified in clause 5.4.1 m),specify the combination resulting in the highest e.i.r.p. for the radio equipment.

Unless otherwise specified in ETSI EN 300 328, this power setting is to be used for testing against the requirements of ETSI EN 300 328. In case there is more than one such conducted power setting resulting in the same (highest) e.i.r.p. level, the highest power setting is to be used for testing. See also ETSI EN 300 328, clause 5.3.2.3.

Highest overall e.i.r.p. value: ..... dBm	
Corresponding Antenna assembly gain: ..... dBi	Antenna Assembly #: .....
Corresponding conducted power setting: ..... dBm (also the power level to be used for testing)	Listed as Power Setting #: .....

**ANNEX E.4.1**

ITU Class(es) of emission: .....

Can the transmitter operate unmodulated? yes  no

**ANNEX E.4.2**

The transmitter is intended for: Continuous duty  
Intermittent duty  
Continuous operation possible for testing purposes

**ANNEX E.4.3**

- The equipment submitted are representative production models
- If not, the equipment submitted are pre-production models?
- If pre-production equipment are submitted, the final production equipment will be identical in all respects with the equipment tested
- If not, supply full details

**ANNEX E.4.4**

- Spare batteries (e.g. for portable equipment)
- Battery charging device
- External Power Supply or AC/DC adapter
- Test jig or interface box
- RF test fixture (for equipment with integrated antennas)
- Combined equipment Manufacturer: .....
- Model #: .....
- Model name: .....
- User Manual
- Technical documentation (Handbook and circuit diagrams)

**3.2 Tested System Details**

None.



3.3 Block Diagram of Test Set-up



3.4 Test Mode Description

Mode	data rate (Mbps)	Channel	Frequency (MHz)
GFSK	1	Low: CH00	2402
	1	Middle: CH39	2441
	1	High: CH78	2480
PI/4 DQPSK	2	Low: CH00	2402
	2	Middle: CH39	2441
	2	High: CH78	2480
8DPSK	3	Low: CH00	2402
	3	Middle: CH39	2441
	3	High: CH78	2480

3.5 Test Conditions

	Normal Conditions	Extreme Conditions	
Temperature range	25°C	HTHV	DC 13.2V, 55°C
		HTLV	DC 10.8V, 55°C
Power supply	DC 12V	LTLV	DC 10.8V, -20°C
		LTHV	DC 13.2V, -20°C

Note 1: The test procedure described in clause 5.1 of EN300 328 was used for extreme test procedure.  
 2: The Extreme Temperature and Extreme Voltages declared by the manufacturer.



## 3.6 Test Uncertainty

Item	MU	Remark
Uncertainty for Conducted Emission Test	2.50dB	
Uncertainty for Radiation Emission test in 3m chamber (30MHz to 1GHz)	3.04dB	Polarize: V
	3.02dB	Polarize: H
Uncertainty for Radiation Emission test in 3m chamber (Above)	3.56dB	Polarize: H
	3.84dB	Polarize: V
Uncertainty for radio frequency	$1 \times 10^{-9}$	
Uncertainty for conducted RF Power	0.65dB	
Uncertainty for temperature	0.6°C	
Uncertainty for humidity	1%	

**4. TEST INSTRUMENT USED**

Equipment	Manufacturer	Model	Serial	Last Cal.	Next Cal.
Comprehensive Tester	ROHDE&SCHWARZ	CMW500	106504	Nov. 05, 2022	Nov. 04, 2023
Spectrum Analyzer	KEYSIGHT	N9020A	MY55370280	Nov. 05, 2022	Nov. 04, 2023
Signal Source	Agilent	N5182A	MY46240766	Nov. 05, 2022	Nov. 04, 2023
Signal Source	Agilent	83752B	3610A01631	Nov. 05, 2022	Nov. 04, 2023
Probe	KEYSIGHT	U2021XA	MY55210018	Nov. 05, 2022	Nov. 04, 2023
Attenuator	MAIWEI	MANASR0206 S2	DLE-160	Nov. 05, 2022	Nov. 04, 2023
RF Control Box	MAIWEI	MW100-RFCB	DLE-179	Nov. 05, 2022	Nov. 04, 2023
RF Control Box	MAIWEI	MW200-RFCB	DLE-180	Nov. 05, 2022	Nov. 04, 2023
RF Cable	MAIWEI	Z302S	18054391	Nov. 05, 2022	Nov. 04, 2023
RF Cable	MAIWEI	Z302S	19051973	Nov. 05, 2022	Nov. 04, 2023
RF Cable	MAIWEI	Z302S	19051987	Nov. 05, 2022	Nov. 04, 2023
RF Cable	MAIWEI	Z302S	19051988	Nov. 05, 2022	Nov. 04, 2023
RF Cable	MAIWEI	Z302S	19063251	Nov. 05, 2022	Nov. 04, 2023
RF Cable	MAIWEI	Z302S	19063254	Nov. 05, 2022	Nov. 04, 2023
RF Cable	MAIWEI	Z302S	19063257	Nov. 05, 2022	Nov. 04, 2023
RF Cable	MAIWEI	Z302S	19063259	Nov. 05, 2022	Nov. 04, 2023
DC power	LODESTAR	LP532DE	LP1908158	Nov. 05, 2022	Nov. 04, 2023
966 chamber	ChengYu	966 Room	966	Sep. 20, 2022	Sep. 19, 2025
Spectrum Analyzer	Agilent	E4408B	MY50140780	Nov. 05, 2022	Nov. 04, 2023
EMI Receiver	R&S	ESRP7	101393	Nov. 05, 2022	Nov. 04, 2023
Amplifier	Schwarzbeck	BBV9743B	00153	Nov. 05, 2022	Nov. 04, 2023
Amplifier	EMEC	EM01G8GA	00270	Nov. 05, 2022	Nov. 04, 2023
Active Loop Antenna	Daze	ZN30900A	SEL0097	Nov. 05, 2022	Nov. 04, 2023
Broadband Trilog Antenna	Schwarzbeck	VULB9162	00306	Nov. 05, 2022	Nov. 04, 2023
Horn Antenna	Schwarzbeck	BBHA9120D	02139	Nov. 05, 2022	Nov. 04, 2023
966 Cable 1#	ChengYu	966	004	Nov. 05, 2022	Nov. 04, 2023
966 Cable 2#	ChengYu	966	003	Nov. 05, 2022	Nov. 04, 2023
Temperature Controller	Terchy	MHQ	120	Nov. 05, 2022	Nov. 04, 2023

## 5. RF OUTPUT POWER

### 5.1 Block Diagram of Test Setup

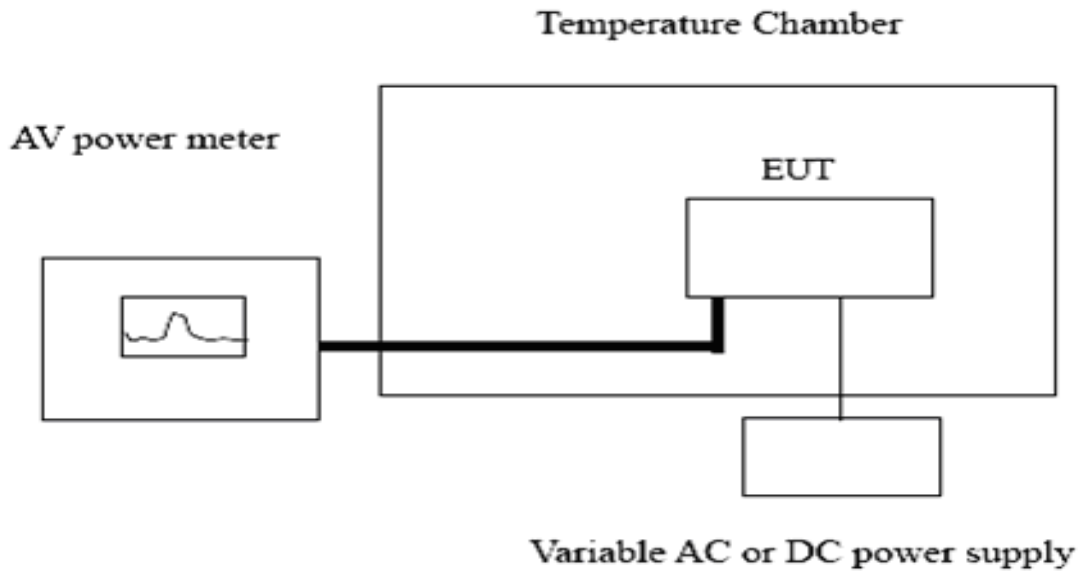

### 5.2 Limit

The RF output power for non-FHSS equipment shall be equal to or less than 20 dBm.

Notes: For Non-adaptive FHSS equipment, the manufacturer may have declared a reduced RF Output Power (see clause 5.4.1 m) and associated Duty Cycle (see clause 5.4.1 e) that will ensure that the equipment meets the requirement for the Medium Utilization (MU) factor further described in clause 4.3.2.5.

This is verified by the conformance test referred to in clause 4.3.2.5.4.

For non-adaptive non-FHSS equipment, where the manufacturer has declared an RF output power of less than 20 dBm e.i.r.p., the RF output power shall be equal to or less than that declared value.

### 5.3 Test Procedure

Refer to ETSI EN 300 328 V2.2.2 Clause 5.4.2.2.1.2



## 5.4 Test Result

Total e.i.r.p (dBm) Result								
Mode	Test CH	Condition					Limit (dBm)	Result
		Normal	HTLV	LTLV	LTHV	HTHV		
GFSK	Low	-1.17	-1.24	-1.17	-1.08	-1.13	20.00	Pass
	Middle	-1.01	-1.22	-1.19	-1.19	-1.02	20.00	Pass
	High	-1.01	-1.11	-1.44	-1.10	-1.05	20.00	Pass
PI/4DQPSK	Low	-1.97	-1.90	-1.85	-1.98	-1.93	20.00	Pass
	Middle	-2.26	-1.88	-2.12	-2.11	-2.21	20.00	Pass
	High	-2.15	-1.86	-2.19	-1.75	-1.89	20.00	Pass
8DPSK	Low	-1.90	-1.89	-1.75	-1.79	-1.86	20.00	Pass
	Middle	-1.81	-1.84	-2.57	-1.98	-1.78	20.00	Pass
	High	-1.80	-1.78	-1.91	-2.02	-1.86	20.00	Pass



## 6. DUTY CYCLE, TX-SEQUENCE, TX-GAP

### 6.1 Block Diagram of Test Setup



### 6.2 Limit

Non-adaptive FHSS equipment shall comply with the following:

- The Duty Cycle shall be equal to or less than the maximum value declared by the manufacturer.
- The maximum Tx-sequence time shall be 5 ms.
- The minimum Tx-gap time shall be 5 ms.

NOTE: For Non-adaptive FHSS equipment, the manufacturer may have declared a reduced RF Output Power (see clause 5.4.1 m) and associated Duty Cycle (see clause 5.4.1 e) that will ensure that the equipment meets the requirements for the Medium Utilization (MU) factors further described in clause 4.3.1.6. This is verified by the conformance test referred to in clause 4.3.1.6.4.

### 6.3 Test Procedure

Refer to ETSI EN 300 328 V2.2.2 Clause 5.4.2.2.1.3

### 6.4 Test Result

The equipment's output power is below 10dBm, no requirements for this item.



## 7. ACCUMULATED TRANSMIT TIME, FREQUENCY OCCUPATION AND HOPPING SEQUENCE

### 7.1 Block Diagram of Test Setup

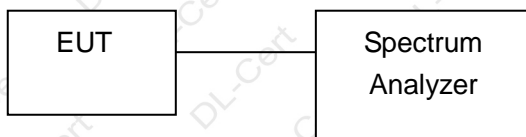

### 7.2 Limit

For Non-adaptive FHSS equipment

The Accumulated Transmit Time on any hopping frequency shall not be greater than 15 ms within any observation period of 15 ms multiplied by the minimum number of hopping frequencies (N) that have to be used.

In order for the FHSS equipment to comply with the Frequency Occupation requirement, it shall meet either of the following two options:

Option 1: Each hopping frequency of the Hopping Sequence shall be occupied at least once within a period not exceeding four times the product of the dwell time and the number of hopping frequencies in use.

Option 2: The probability that each hopping frequency is occupied shall be between  $((1 / U) \times 25 \%)$  and 77 % where U is the number of hopping frequencies in use.

The Hopping Sequence(s) shall contain at least N hopping frequencies where N is either 5 or the result of 15 MHz divided by the minimum Hopping Frequency Separation in MHz, whichever is the greater.

NOTE: See also clause 4.3.1.5.3.1 for the Hopping Frequency Separation applicable to non-adaptive FHSS equipment.

Non-Adaptive FHSS equipment, may blacklist some but not all hopping frequencies. From the N hopping frequencies defined above, the equipment shall transmit on at least one hopping frequency. For the blacklisted frequencies, the equipment has to occupy these frequencies for the duration of the average dwell time (see also definition for blacklisted frequency in clause 3.1).

For Adaptive FHSS equipment

Adaptive FHSS equipment shall be capable of operating over a minimum of 70 % of the band specified in table 1.

The Accumulated Transmit Time on any hopping frequency shall not be greater than 400 ms within any observation period of 400 ms multiplied by the minimum number of hopping frequencies (N) that have to be used.

In order for the FHSS equipment to comply with the Frequency Occupation requirement, it shall meet either of the following two options:

Option 1: Each hopping frequency of the Hopping Sequence shall be occupied at least once within a period not exceeding four times the product of the dwell time and the number of hopping frequencies in use.

Option 2: The occupation probability for each frequency shall be between  $((1 / U) \times 25 \%)$  and 77 % where U is the number of hopping frequencies in use.

The Hopping Sequence(s) shall contain at least N hopping frequencies at all times, where N is either 15 or the result of 15 MHz divided by the minimum Hopping Frequency Separation in MHz, whichever is the greater.



NOTE: See also clause 4.3.1.5.3.2 for the Hopping Frequency Separation applicable to adaptive FHSS equipment.

For Adaptive FHSS equipment, from the N hopping frequencies defined above, the equipment shall consider at least one hopping frequency for its transmissions. Providing that there is no interference present on this hopping frequency with a level above the detection threshold defined in clause 4.3.1.7.2.2, point 5 or clause 4.3.1.7.3.2, point 5, then the equipment shall have transmissions on this hopping frequency. For Adaptive FHSS equipment using LBT, if a signal is detected during the CCA, the equipment may jump immediately to the next hopping frequency in the Hopping Sequence (see clause 4.3.1.7.2.2, point 2) provided the limit for Accumulated Transmit Time on the new hopping frequency is respected.

7.3 Test Procedure

Refer to ETSI EN 300 328 V2.2.2 Clause 5.4.4

7.4 Test Result

Mode	Channel	Pulse time (ms)	Dwell time(ms)	Mini frequency occupation Time(ms)	Dwell time Limit (ms)	Number of hopping channel	Result
GFSK	Low	0.42	134.40	537.60	<400ms	79	Pass
	Middle	0.42	134.40	537.60			Pass
	High	0.42	134.40	537.60			Pass
PI/4 DQPSK	Low	1.51	241.60	966.40			Pass
	Middle	1.51	241.60	966.40			Pass
	High	1.51	241.60	966.40			Pass
8DPSK	Low	2.34	249.60	998.40			Pass
	Middle	2.34	249.60	998.40			Pass
	High	2.34	249.60	998.40			Pass

Note1:  $DH1=1600/(79*(DH))^*79*0.4$  Pulse time .(DH1=2, DH3=4, DH5=6)  
 2: Mini frequency occupation Time(ms)=4\*Dwell time(ms)

Mode	Operating hopping Bandwidth (MHz)	Hopping sequence	Limit	Result
GFSK	79.85	95.63%	>70%	Pass
PI/4 DQPSK	79.92	95.71%		Pass
8DPSK	79.89	95.68%		Pass

Note1: Hopping Sequence(%) = (20dB BW/83.5)\*100



## 8. HOPPING FREQUENCY SEPARATION

### 8.1 Block Diagram of Test Setup

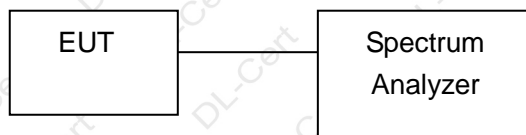

### 8.2 Limit

For Non-adaptive FHSS equipment:

For non-adaptive FHSS equipment, the Hopping Frequency Separation shall be equal to or greater than the Occupied Channel Bandwidth (see clause 4.3.1.8), with a minimum separation of 100 kHz.

For FHSS equipment with a maximum declared RF Output power level of less than 10 dBm e.i.r.p. or for non-adaptive FHSS equipment operating in a mode where the RF Output power is less than 10 dBm e.i.r.p., the Hopping Frequency Separation shall be equal to or greater than 100 kHz.

For Adaptive FHSS equipment:

For adaptive FHSS equipment, the minimum Hopping Frequency Separation shall be 100 kHz.

Adaptive FHSS equipment that switched to a non-adaptive mode for one or more hopping frequencies because interference was detected on each of these hopping frequencies with a level above the threshold level defined in clause 4.3.1.7.2.2, point 5 or clause 4.3.1.7.3.2, point 5, does not have to comply with the Hopping Frequency Separation provided in clause 4.3.1.5.3.1 for non-adaptive FHSS equipment. If the Hopping Frequency Separation is below the Occupied Channel Bandwidth but greater than 100 kHz, the equipment is allowed to continue to operate with this Hopping Frequency Separation as long as the interference remains present on these hopping frequencies. As this relaxed Hopping Frequency Separation only applies to adaptive FHSS equipment, the FHSS equipment shall continue to operate in an adaptive mode on all other hopping frequencies.

Adaptive FHSS equipment which decided to operate in a non-adaptive mode on one or more hopping frequencies without the presence of interference, shall comply with the limit for Hopping Frequency Separation for non-adaptive FHSS equipment defined in clause 4.3.1.5.3.1 (first paragraph) for these hopping frequencies.

### 8.3 Test Procedure

Refer to ETSI EN 300 328 V2.2.2 Clause 5.4.5



## 8.4 Test Result

Mode	Channel	Frequency Separation	Limit (MHz)	Result
GFSK	Low	1.029	>0.1	Pass
	Middle	0.974	>0.1	Pass
	High	0.954	>0.1	Pass
PI/4 DQPSK	Low	0.983	>0.1	Pass
	Middle	0.995	>0.1	Pass
	High	1.107	>0.1	Pass
8DPSK	Low	0.962	>0.1	Pass
	Middle	0.916	>0.1	Pass
	High	1.002	>0.1	Pass

## 9. ADAPTIVITY

### 9.1 Block Diagram of Test Setup

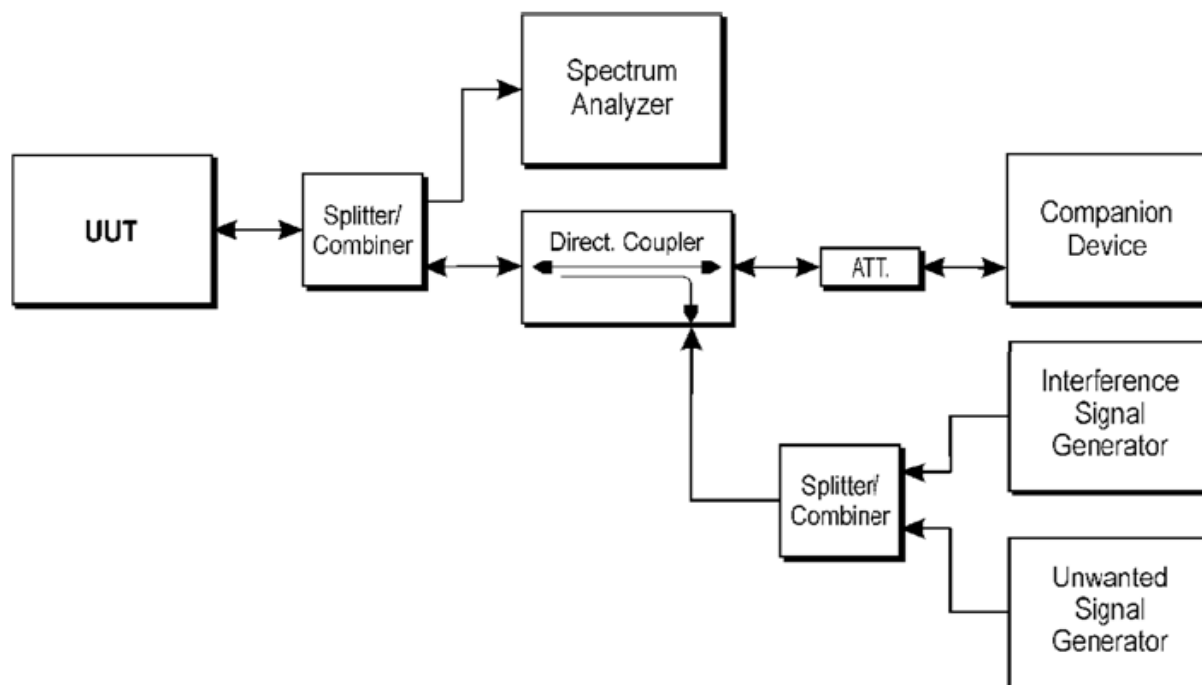

**Figure 5: Test set-up for verifying the adaptivity of an equipment**

### 9.2 Limit

Adaptive FHSS equipment using LBT shall comply with the following minimum set of requirements:

- 1) At the start of every dwell time, before transmission on a hopping frequency, the equipment shall perform a Clear Channel Assessment (CCA) check using energy detect. The CCA observation time shall be not less than 0,2 % of the Channel Occupancy Time with a minimum of 18  $\mu$ s. If the equipment finds the hopping frequency to be clear, it may transmit immediately.
- 2) If it is determined that a signal is present with a level above the detection threshold defined in step 5 the hopping frequency shall be marked as 'unavailable'. Then the equipment may jump to the next frequency in the hopping scheme even before the end of the dwell time, but in that case the 'unavailable' channel cannot be considered as being 'occupied' and shall be disregarded with respect to the requirement of the minimum number of hopping frequencies as defined in clause 4.3.1.4.3.2. Alternatively, the equipment can remain on the frequency during the remainder of the dwell time. However, if the equipment remains on the frequency with the intention to transmit, it shall perform an Extended CCA check in which the (unavailable) channel is observed for a random duration between the value defined for the CCA observation time in step 1 and 5 % of the Channel Occupancy Time defined in step 3. If the Extended CCA check has determined the frequency to be no longer occupied, the hopping frequency becomes available again. If the Extended CCA time has determined the channel still to be occupied, it shall perform new Extended CCA checks until the channel is no longer occupied.
- 3) The total time during which an equipment has transmissions on a given hopping frequency without reevaluating the availability of that frequency is defined as the Channel Occupancy Time. The Channel Occupancy Time for a given hopping frequency, which starts immediately after a successful CCA, shall be



less than 60 ms followed by an Idle Period of minimum 5 % of the Channel Occupancy Time with a minimum of 100  $\mu$ s.

After the Idle Period has expired, the procedure as in step 1 shall be repeated before having new transmissions on this hopping frequency during the same dwell time.

For LBT based adaptive FHSS equipment with a dwell time < 60 ms, the maximum Channel Occupancy Time is limited by the dwell time.

4) 'Unavailable' channels may be removed from or may remain in the Hopping Sequence, but in any case:

- apart from Short Control Signalling Transmissions referred to in clause 4.3.1.7.4, there shall be no transmissions on 'unavailable' channels;

- a minimum of N hopping frequencies as defined in clause 4.3.1.4.3.2 shall always be maintained.

5) The detection threshold shall be proportional to the transmit power of the transmitter: for a 20 dBm e.i.r.p. transmitter the detection threshold level (TL) shall be equal to or less than -70 dBm/MHz at the input to the receiver assuming a 0 dBi (receive) antenna assembly. This threshold level (TL) may be corrected for the (receive) antenna assembly gain (G); however, beamforming gain (Y) shall not be taken into account. For power levels less than 20 dBm e.i.r.p., the detection threshold level may be relaxed to:

$$TL = -70 \text{ dBm/MHz} + 10 \times \log_{10} (100 \text{ mW} / P_{\text{out}}) \quad (P_{\text{out}} \text{ in mW e.i.r.p.})$$

6) The equipment shall comply with the requirements defined in step 1 to step 4 of the present clause in the presence of an unwanted CW signal as defined in table 2.

**Table 2: Unwanted Signal parameters**

Wanted signal mean power from companion device	Unwanted CW signal frequency (MHz)	Unwanted CW signal power (dBm)
sufficient to maintain the link (see note 2)	2 395 or 2 488,5 (see note 1)	-35 (see note 3)
NOTE 1: The highest frequency shall be used for testing operating channels within the range 2 400 MHz to 2 442 MHz, while the lowest frequency shall be used for testing operating channels within the range 2 442 MHz to 2 483,5 MHz. See clause 5.4.6.1.		
NOTE 2: A typical conducted value which can be used in most cases is -50 dBm/MHz.		
NOTE 3: The level specified is the level at the UUT receiver input assuming a 0 dBi antenna assembly gain. In case of conducted measurements, this level has to be corrected for the (in-band) antenna assembly gain (G). In case of radiated measurements, this level is equivalent to a power flux density (PFD) in front of the UUT antenna.		

### 9.3 Test Procedure

Refer to ETSI EN 300 328 V2.2.2 Clause 5.4.6

### 9.4 Test Result

Not applicable

Note: The maximum output power of EUT less than 10dBm, so not applicable.



### 10. OCCUPIED CHANNEL BANDWIDTH

#### 10.1 Block Diagram of Test Setup

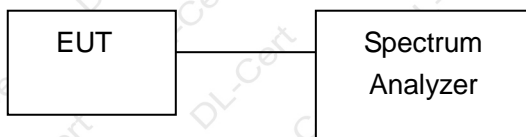

#### 10.2 Limit

The Occupied Channel Bandwidth shall be within the band given in 2.4GHz to 2.4835GHz..

In addition, for non-adaptive non-FHSS equipment with e.i.r.p. greater than 10 dBm, the Occupied Channel Bandwidth shall be equal to or less than 20MHz.

#### 10.3 Test Procedure

Refer to ETSI EN 300 328 V2.2.2 Clause 5.4.7

Connect the UUT to the spectrum analyzer and use the following settings:

Centre Frequency:	The centre frequency of the channel under test
RBW	~ 1 % of the span without going below 1 %
VBW	3 × RBW
Frequency Span:	2 × Nominal Channel Bandwidth
Detector Mode:	RMS
Trace Mode:	Max Hold
Sweep time:	1s

#### 10.4 Test Result

Test Mode	Test Channel	Occupied Bandwidth	Measured Frequency		Limit	Result
			F <sub>L</sub> (MHz)	F <sub>H</sub> (MHz)		
GFSK	Low	0.852	2401.557	/	>2400MHz And <2483.5MHz	Pass
	High	0.855	/	2480.414		Pass
PI/4 DQPSK	Low	1.158	2401.391	/	>2400MHz And <2483.5MHz	Pass
	High	1.160	/	2480.567		Pass
8DPSK	Low	1.162	2401.395	/	>2400MHz And <2483.5MHz	Pass
	High	1.165	/	2480.565		Pass



### 11. TRANSMITTER UNWANTED EMISSIONS IN THE OUT-OF-BAND DOMAIN

#### 11.1 Block Diagram of Test Setup

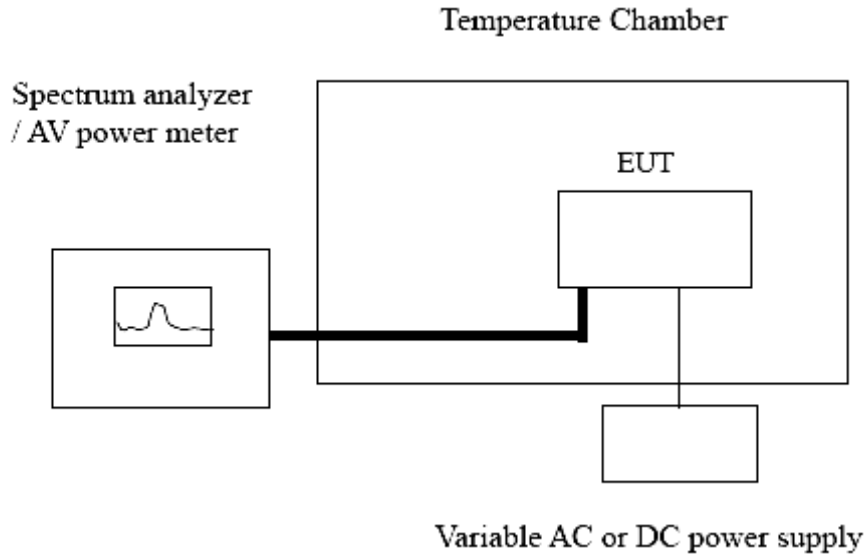

#### 11.2 Limit

The transmitter unwanted emissions in the out-of-band domain shall not exceed the values provided by the mask in figure 3.

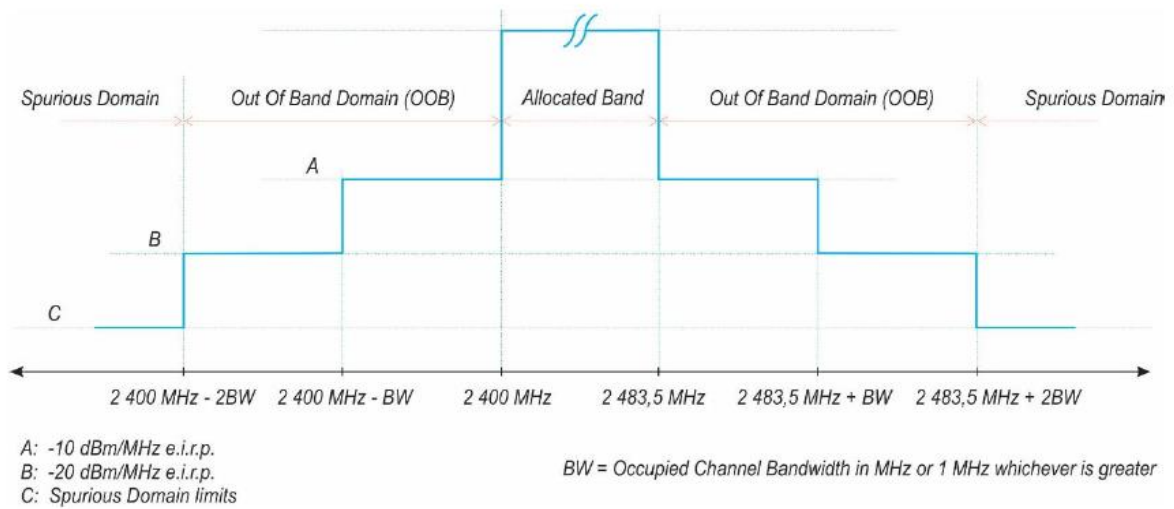

Figure 3: Transmit mask



### 11.3 Test Procedure

Refer to ETSI EN 300 328 V2.2.0 Clause 5.4.8.

Connect the UUT to the spectrum analyzer and use the following settings:

RBW/VBW	1MHz/3MHz
Span	0Hz
Filter mode	Channel filter
Sweep mode	Continuous
Sweep Points	5000
Detector	RMS
Trace mode	Clear/Write
Trigger Mode	Video trigger

### 11.4 Test Result

Test Mode	Test Condition	Lower Band Edge		Higher Band Edge	
		Segment A (dBm/MHz)	Segment B (dBm/MHz)	Segment A (dBm/MHz)	Segment B (dBm/MHz)
GFSK	Normal	-67.13	-59.85	-67.73	-67.79
PI/4 DQPSK	Normal	-54.63	-60.45	-68.11	-66.78
8DPSK	Normal	-66.18	-67.29	-66.73	-67.71
Limit		-10	-20	-10	-20
Conclusion		PASS			
Remark1: All modulations of EUT have been tested, but only show the test data of the worst case in this report. 2: The plots only show the worst mode data.					



### GFSK Channel

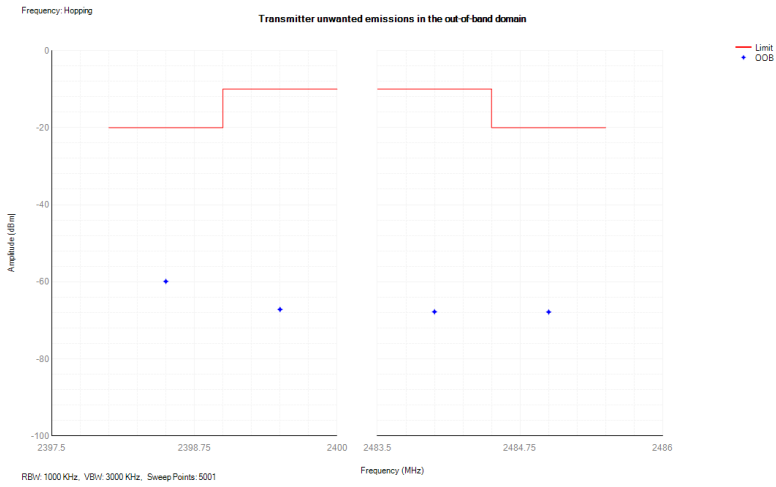

### PI/4 DQPSK Channel

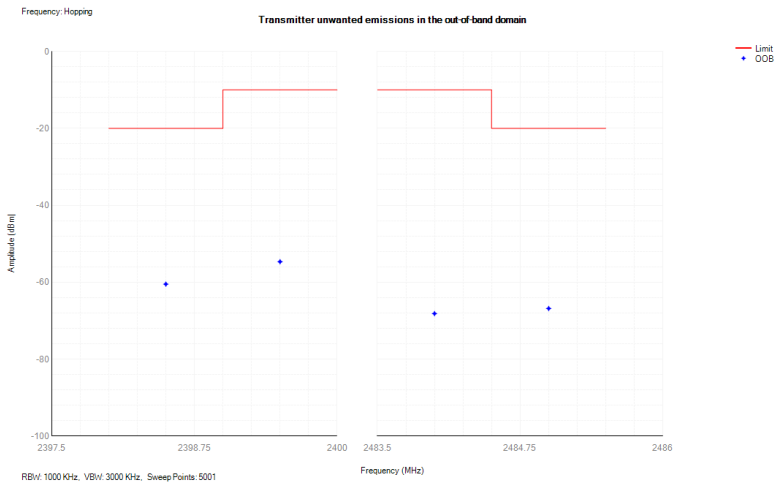

### 8DPSK Channel

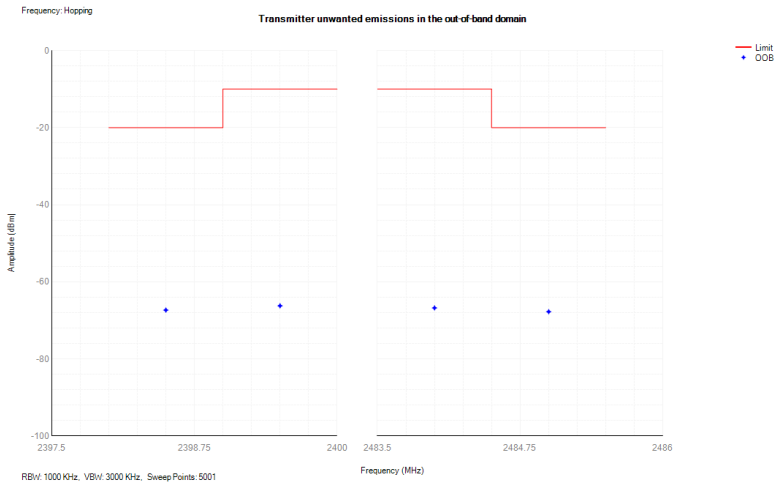

## 12. TRANSMITTER UNWANTED EMISSIONS IN THE SPURIOUS DOMAIN

### 12.1 Block Diagram of Test Setup

Below 1GHz

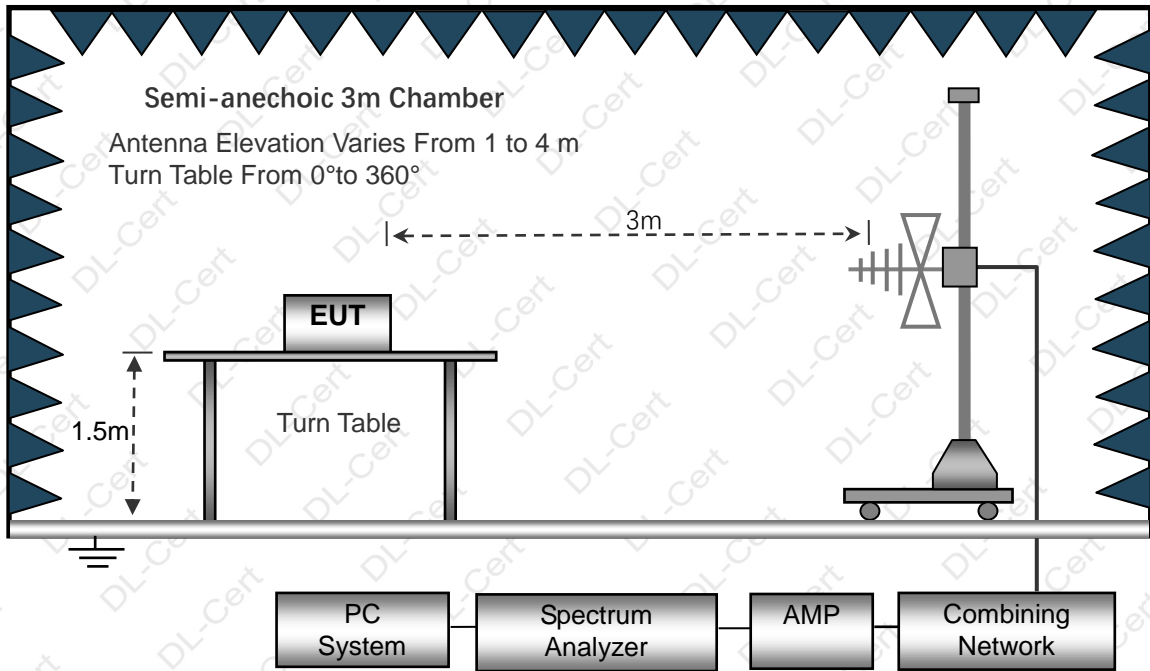

Above 1GHz

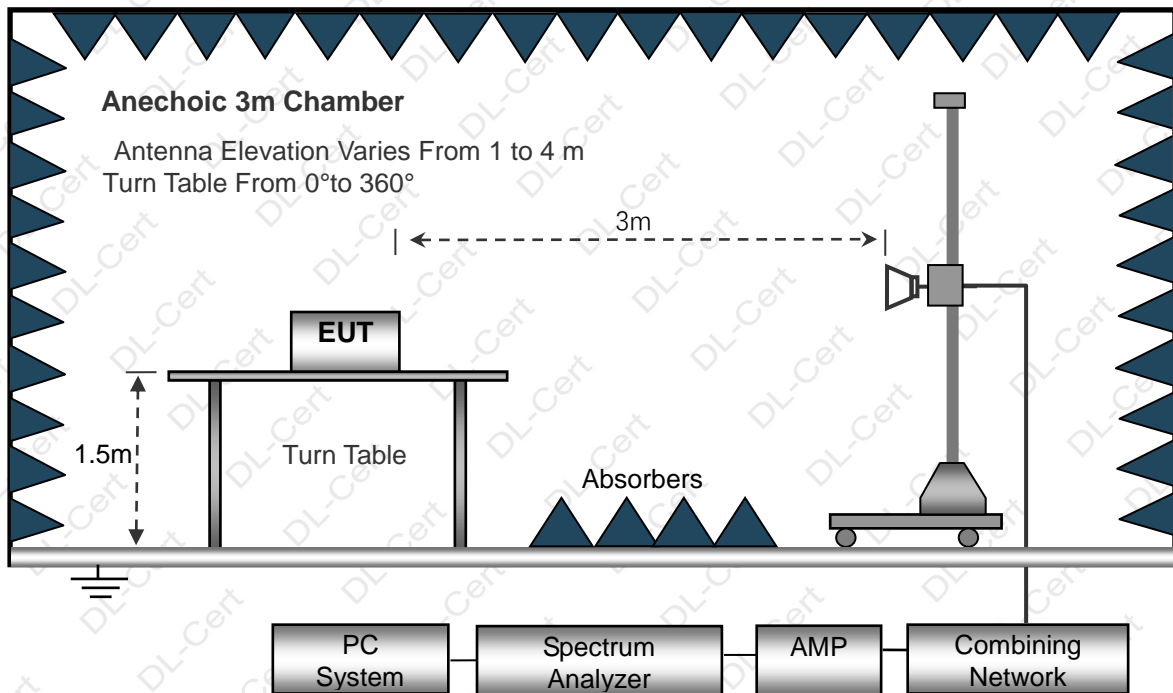



12.2 Limit

The transmitter unwanted emissions in the spurious domain shall not exceed the values given in table 12.

**Table 12: Transmitter limits for spurious emissions**

Frequency range	Maximum power	Bandwidth
30 MHz to 47 MHz	-36 dBm	100 kHz
47 MHz to 74 MHz	-54 dBm	100 kHz
74 MHz to 87,5 MHz	-36 dBm	100 kHz
87,5 MHz to 118 MHz	-54 dBm	100 kHz
118 MHz to 174 MHz	-36 dBm	100 kHz
174 MHz to 230 MHz	-54 dBm	100 kHz
230 MHz to 470 MHz	-36 dBm	100 kHz
470 MHz to 694 MHz	-54 dBm	100 kHz
694 MHz to 1 GHz	-36 dBm	100 kHz
1 GHz to 12,75 GHz	-30 dBm	1 MHz

12.3 Test Procedure

Refer to ETSI EN 300 328 V2.2.0 Clause 5.4.9.

12.4 Test Result

Below 1GHz

Spurious Emission Test Data					
Frequency (MHz)	Polarization	Level (dBm)	Limit (dBm)	Marging (dB)	Result
32.73	Vertical	-63.44	-36	-27.44	Pass
66.19	Vertical	-66.01	-54	-12.01	Pass
173.27	Vertical	-61.90	-36	-25.90	Pass
397.19	Vertical	-64.88	-36	-28.88	Pass
669.25	Vertical	-65.41	-54	-11.41	Pass
971.59	Vertical	-61.75	-36	-25.75	Pass
41.63	Horizontal	-62.60	-36	-26.60	Pass
180.37	Horizontal	-67.18	-54	-13.18	Pass
211.74	Horizontal	-66.62	-54	-12.62	Pass
452.55	Horizontal	-64.54	-36	-28.54	Pass
503.76	Horizontal	-63.79	-54	-9.79	Pass
955.79	Horizontal	-63.85	-36	-27.85	Pass



Above 1GHz

Spurious Emission Test Data						
Mode	Frequency (MHz)	Polarization	Level (dBm)	Limit (dBm)	Margin (dB)	Result
GFSK Low Channel	4804	Vertical	-37.73	-30.00	-7.73	Pass
	7206	Vertical	-39.99	-30.00	-9.99	Pass
	9608	Vertical	-42.56	-30.00	-12.56	Pass
	4804	Horizontal	-37.92	-30.00	-7.92	Pass
	7206	Horizontal	-41.15	-30.00	-11.15	Pass
	9608	Horizontal	-41.54	-30.00	-11.54	Pass
GFSK Middle Channel	4882	Vertical	-37.66	-30.00	-7.66	Pass
	7323	Vertical	-39.52	-30.00	-9.52	Pass
	9764	Vertical	-42.26	-30.00	-12.26	Pass
	4882	Horizontal	-36.94	-30.00	-6.94	Pass
	7323	Horizontal	-40.58	-30.00	-10.58	Pass
	9764	Horizontal	-41.64	-30.00	-11.64	Pass
GFSK High Channel	4960	Vertical	-37.30	-30.00	-7.30	Pass
	7440	Vertical	-38.97	-30.00	-8.97	Pass
	9920	Vertical	-41.23	-30.00	-11.23	Pass
	4960	Horizontal	-37.28	-30.00	-7.28	Pass
	7440	Horizontal	-40.09	-30.00	-10.09	Pass
	9920	Horizontal	-42.49	-30.00	-12.49	Pass
PI/4 DQPSK Low Channel	4804	Vertical	-37.32	-30.00	-7.32	Pass
	7206	Vertical	-39.56	-30.00	-9.56	Pass
	9608	Vertical	-42.10	-30.00	-12.10	Pass
	4804	Horizontal	-37.51	-30.00	-7.51	Pass
	7206	Horizontal	-40.71	-30.00	-10.71	Pass
	9608	Horizontal	-41.10	-30.00	-11.10	Pass
PI/4 DQPSK Middle Channel	4882	Vertical	-37.25	-30.00	-7.25	Pass
	7323	Vertical	-39.10	-30.00	-9.10	Pass
	9764	Vertical	-43.53	-30.00	-13.53	Pass
	4882	Horizontal	-36.54	-30.00	-6.54	Pass
	7323	Horizontal	-40.12	-30.00	-10.12	Pass
	9764	Horizontal	-41.04	-30.00	-11.04	Pass
PI/4 DQPSK High Channel	4960	Vertical	-36.87	-30.00	-6.87	Pass
	7440	Vertical	-38.53	-30.00	-8.53	Pass
	9920	Vertical	-41.57	-30.00	-11.57	Pass
	4960	Horizontal	-36.87	-30.00	-6.87	Pass
	7440	Horizontal	-39.66	-30.00	-9.66	Pass
	9920	Horizontal	-41.29	-30.00	-11.29	Pass



Spurious Emission Test Data						
Mode	Frequency (MHz)	Polarization	Level (dBm)	Limit (dBm)	Margin (dB)	Result
8DPSK Low Channel	4804	Vertical	-38.27	-30.00	-8.27	Pass
	7206	Vertical	-40.58	-30.00	-10.58	Pass
	9608	Vertical	-43.19	-30.00	-13.19	Pass
	4804	Horizontal	-38.48	-30.00	-8.48	Pass
	7206	Horizontal	-41.76	-30.00	-11.76	Pass
	9608	Horizontal	-43.78	-30.00	-13.78	Pass
8DPSK Middle Channel	4882	Vertical	-38.20	-30.00	-8.20	Pass
	7323	Vertical	-40.09	-30.00	-10.09	Pass
	9764	Vertical	-44.65	-30.00	-14.65	Pass
	4882	Horizontal	-37.45	-30.00	-7.45	Pass
	7323	Horizontal	-41.15	-30.00	-11.15	Pass
	9764	Horizontal	-43.88	-30.00	-13.88	Pass
8DPSK High Channel	4960	Vertical	-37.80	-30.00	-7.80	Pass
	7440	Vertical	-39.50	-30.00	-9.50	Pass
	9920	Vertical	-42.63	-30.00	-12.63	Pass
	4960	Horizontal	-37.79	-30.00	-7.79	Pass
	7440	Horizontal	-40.67	-30.00	-10.67	Pass
	9920	Horizontal	-42.18	-30.00	-12.18	Pass

### 13. RECEIVER SPURIOUS EMISSIONS

#### 13.1 Block Diagram of Test Setup

Below 1GHz

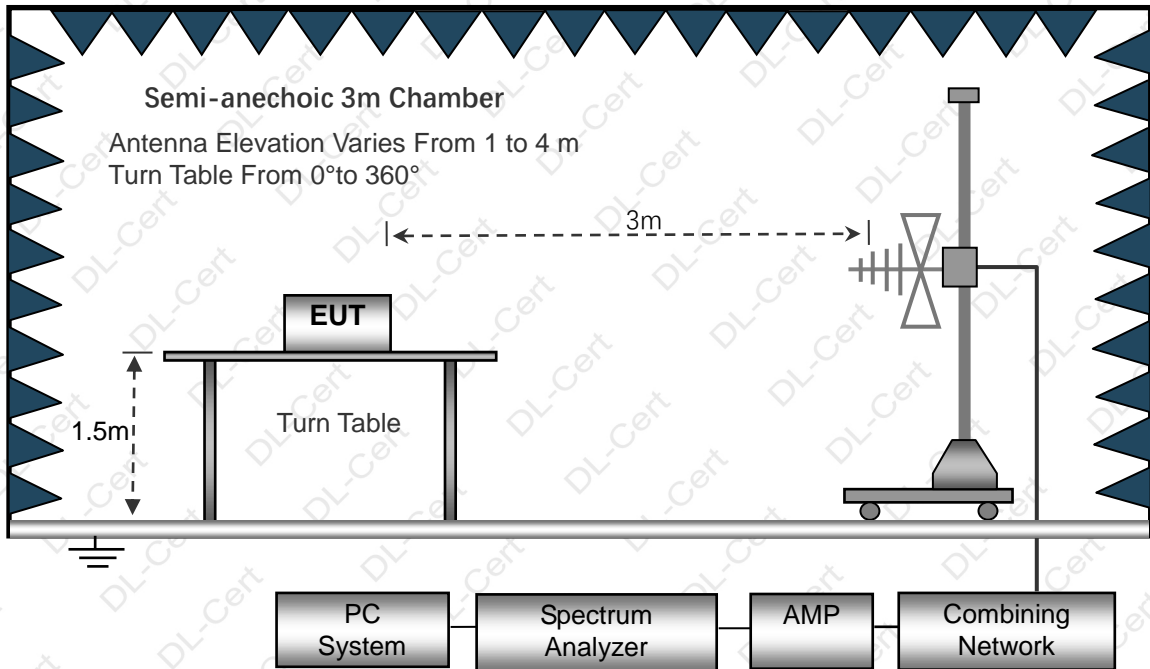

Above 1GHz

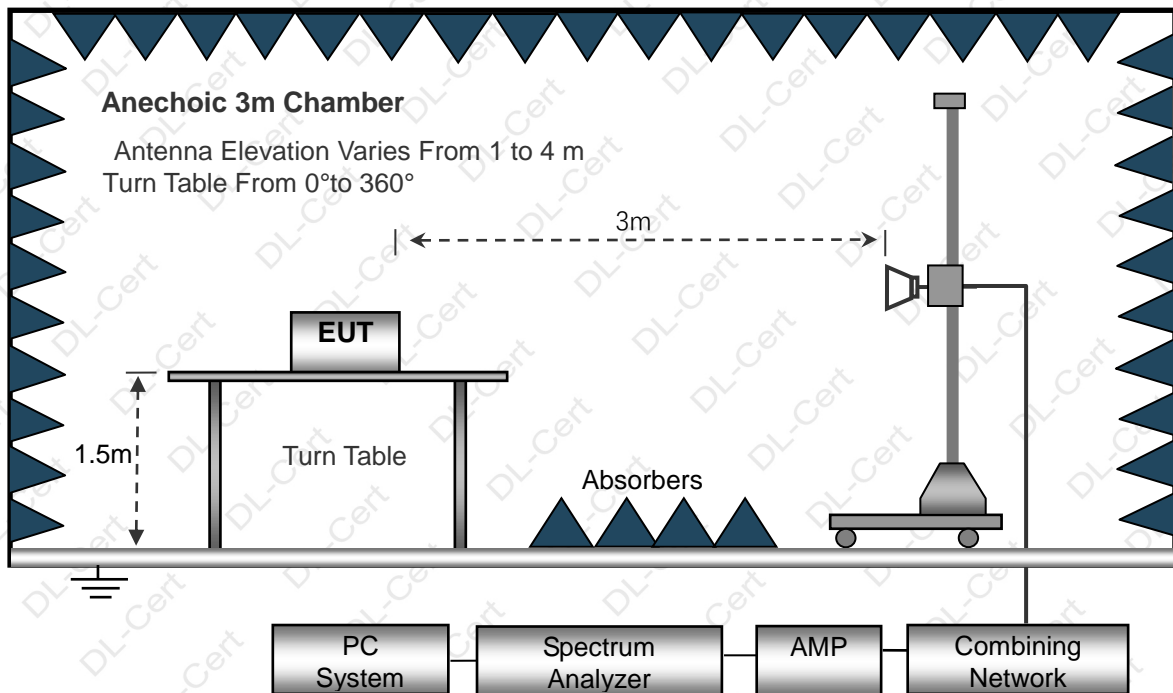



### 13.2 Limit

The spurious emissions of the receiver shall not exceed the values given in table 13.

**Table 13: Spurious emission limits for receivers**

Frequency range	Maximum power	Bandwidth
30 MHz to 1 GHz	-57 dBm	100 kHz
1 GHz to 12,75 GHz	-47 dBm	1 MHz

### 13.3 Test Procedure

Refer to ETSI EN 300 328 V2.2.0 Clause 5.4.9.

### 13.4 Test Result

Below 1GHz

Receiver Spurious Emissions Test Data					
Frequency (MHz)	Polarization	Level (dBm)	Limit (dBm)	Marging (dB)	Result
34.03	Vertical	-69.88	-57.00	-12.88	Pass
113.80	Vertical	-70.95	-57.00	-13.95	Pass
167.36	Vertical	-70.94	-57.00	-13.94	Pass
216.90	Vertical	-70.91	-57.00	-13.91	Pass
712.78	Vertical	-70.97	-57.00	-13.97	Pass
899.86	Vertical	-70.52	-57.00	-13.52	Pass
33.72	Horizontal	-71.16	-57.00	-14.16	Pass
86.08	Horizontal	-70.50	-57.00	-13.50	Pass
135.52	Horizontal	-71.69	-57.00	-14.69	Pass
215.54	Horizontal	-72.96	-57.00	-15.96	Pass
493.05	Horizontal	-71.50	-57.00	-14.50	Pass
859.20	Horizontal	-71.72	-57.00	-14.72	Pass



Above 1GHz

Receiver Spurious Emissions Test Data						
Mode	Frequency (MHz)	Polarization	Level (dBm)	Limit (dBm)	Margin (dB)	Result
GFSK Low Channel	4804	Vertical	-56.29	-47.00	-9.29	Pass
	7206	Vertical	-55.76	-47.00	-8.76	Pass
	9608	Vertical	-57.09	-47.00	-10.09	Pass
	4804	Horizontal	-56.11	-47.00	-9.11	Pass
	7206	Horizontal	-55.57	-47.00	-8.57	Pass
	9608	Horizontal	-57.75	-47.00	-10.75	Pass
GFSK Middle Channel	4882	Vertical	-58.04	-47.00	-11.04	Pass
	7323	Vertical	-57.21	-47.00	-10.21	Pass
	9764	Vertical	-55.54	-47.00	-8.54	Pass
	4882	Horizontal	-56.45	-47.00	-9.45	Pass
	7323	Horizontal	-59.34	-47.00	-12.34	Pass
	9764	Horizontal	-56.86	-47.00	-9.86	Pass
GFSK High Channel	4960	Vertical	-57.80	-47.00	-10.80	Pass
	7440	Vertical	-60.00	-47.00	-13.00	Pass
	9920	Vertical	-56.44	-47.00	-9.44	Pass
	4960	Horizontal	-55.88	-47.00	-8.88	Pass
	7440	Horizontal	-55.68	-47.00	-8.68	Pass
	9920	Horizontal	-57.80	-47.00	-10.80	Pass
PI/4DQPSK Low Channel	4804	Vertical	-55.84	-47.00	-8.84	Pass
	7206	Vertical	-56.69	-47.00	-9.69	Pass
	9608	Vertical	-58.02	-47.00	-11.02	Pass
	4804	Horizontal	-57.07	-47.00	-10.07	Pass
	7206	Horizontal	-56.49	-47.00	-9.49	Pass
	9608	Horizontal	-56.80	-47.00	-9.80	Pass
PI/4DQPSK Middle Channel	4882	Vertical	-58.04	-47.00	-11.04	Pass
	7323	Vertical	-56.27	-47.00	-9.27	Pass
	9764	Vertical	-57.41	-47.00	-10.41	Pass
	4882	Horizontal	-57.36	-47.00	-10.36	Pass
	7323	Horizontal	-56.51	-47.00	-9.51	Pass
	9764	Horizontal	-57.03	-47.00	-10.03	Pass
PI/4DQPSK High Channel	4960	Vertical	-56.85	-47.00	-9.85	Pass
	7440	Vertical	-57.19	-47.00	-10.19	Pass
	9920	Vertical	-56.44	-47.00	-9.44	Pass
	4960	Horizontal	-55.88	-47.00	-8.88	Pass
	7440	Horizontal	-55.68	-47.00	-8.68	Pass
	9920	Horizontal	-57.80	-47.00	-10.80	Pass



Receiver Spurious Emissions Test Data						
Mode	Frequency (MHz)	Polarization	Level (dBm)	Limit (dBm)	Margin (dB)	Result
8DPSK Low Channel	4804	Vertical	-56.19	-47.00	-9.19	Pass
	7206	Vertical	-56.11	-47.00	-9.11	Pass
	9608	Vertical	-57.82	-47.00	-10.82	Pass
	4804	Horizontal	-55.51	-47.00	-8.51	Pass
	7206	Horizontal	-56.66	-47.00	-9.66	Pass
	9608	Horizontal	-57.72	-47.00	-10.72	Pass
8DPSK Middle Channel	4882	Vertical	-57.47	-47.00	-10.47	Pass
	7323	Vertical	-57.57	-47.00	-10.57	Pass
	9764	Vertical	-55.87	-47.00	-8.87	Pass
	4882	Horizontal	-55.84	-47.00	-8.84	Pass
	7323	Horizontal	-56.83	-47.00	-9.83	Pass
	9764	Horizontal	-56.21	-47.00	-9.21	Pass
8DPSK High Channel	4960	Vertical	-57.19	-47.00	-10.19	Pass
	7440	Vertical	-56.51	-47.00	-9.51	Pass
	9920	Vertical	-55.79	-47.00	-8.79	Pass
	4960	Horizontal	-56.30	-47.00	-9.30	Pass
	7440	Horizontal	-58.00	-47.00	-11.00	Pass
	9920	Horizontal	-57.21	-47.00	-10.21	Pass



14. RECEIVER BLOCKING

14.1 Block Diagram of Test Setup

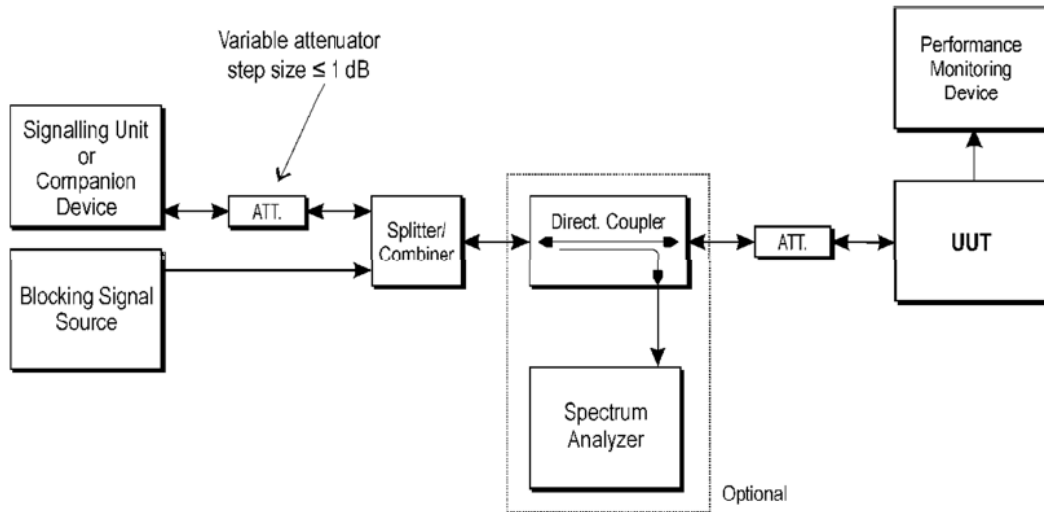

14.2 Limit

Table 14 contains the Receiver Blocking parameters for Receiver Category 1 equipment.

Table 14: Receiver Blocking parameters for Receiver Category 1 equipment

Wanted signal mean power from companion device (dBm) (see notes 1 and 4)	Blocking signal frequency (MHz)	Blocking signal power (dBm) (see note 4)	Type of blocking signal
$(-133 \text{ dBm} + 10 \times \log_{10}(\text{OCBW}))$ or $-68 \text{ dBm}$ whichever is less (see note 2)	2 380 2 504	-34	CW
$(-139 \text{ dBm} + 10 \times \log_{10}(\text{OCBW}))$ or $-74 \text{ dBm}$ whichever is less (see note 3)	2 300 2 330 2 360 2 524 2 584 2 674		
NOTE 1: OCBW is in Hz.			
NOTE 2: In case of radiated measurements using a companion device and the level of the wanted signal from the companion device cannot be determined, a relative test may be performed using a wanted signal up to $P_{\text{min}} + 26 \text{ dB}$ where $P_{\text{min}}$ is the minimum level of wanted signal required to meet the minimum performance criteria as defined in clause 4.3.1.12.3 in the absence of any blocking signal.			
NOTE 3: In case of radiated measurements using a companion device and the level of the wanted signal from the companion device cannot be determined, a relative test may be performed using a wanted signal up to $P_{\text{min}} + 20 \text{ dB}$ where $P_{\text{min}}$ is the minimum level of wanted signal required to meet the minimum performance criteria as defined in clause 4.3.1.12.3 in the absence of any blocking signal.			
NOTE 4: The level specified is the level at the UUT receiver input assuming a 0 dBi antenna assembly gain. In case of conducted measurements, this level has to be corrected for the (in-band) antenna assembly gain (G). In case of radiated measurements, this level is equivalent to a power flux density (PFD) in front of the UUT antenna with the UUT being configured/positioned as recorded in clause 5.4.3.2.2.			



Table 15 contains the Receiver Blocking parameters for Receiver Category 2 equipment.

**Table 15: Receiver Blocking parameters receiver Category 2 equipment**

Wanted signal mean power from companion device (dBm) (see notes 1 and 3)	Blocking signal frequency (MHz)	Blocking signal power (dBm) (see note 3)	Type of blocking signal
$(-139 \text{ dBm} + 10 \times \log_{10}(\text{OCBW}) + 10 \text{ dB})$ or $(-74 \text{ dBm} + 10 \text{ dB})$ whichever is less (see note 2)	2 380 2 504 2 300 2 584	-34	CW
NOTE 1: OCBW is in Hz. NOTE 2: In case of radiated measurements using a companion device and the level of the wanted signal from the companion device cannot be determined, a relative test may be performed using a wanted signal up to $P_{\min} + 26 \text{ dB}$ where $P_{\min}$ is the minimum level of wanted signal required to meet the minimum performance criteria as defined in clause 4.3.1.12.3 in the absence of any blocking signal. NOTE 3: The level specified is the level at the UUT receiver input assuming a 0 dBi antenna assembly gain. In case of conducted measurements, this level has to be corrected for the (in-band) antenna assembly gain (G). In case of radiated measurements, this level is equivalent to a power flux density (PFD) in front of the UUT antenna with the UUT being configured/positioned as recorded in clause 5.4.3.2.2.			

Table 16 contains the Receiver Blocking parameters for Receiver Category 3 equipment.

**Table 16: Receiver Blocking parameters receiver Category 3 equipment**

Wanted signal mean power from companion device (dBm) (see notes 1 and 3)	Blocking signal frequency (MHz)	Blocking signal power (dBm) (see note 3)	Type of blocking signal
$(-139 \text{ dBm} + 10 \times \log_{10}(\text{OCBW}) + 20 \text{ dB})$ or $(-74 \text{ dBm} + 20 \text{ dB})$ whichever is less (see note 2)	2 380 2 504 2 300 2 584	-34	CW
NOTE 1: OCBW is in Hz. NOTE 2: In case of radiated measurements using a companion device and the level of the wanted signal from the companion device cannot be determined, a relative test may be performed using a wanted signal up to $P_{\min} + 30 \text{ dB}$ where $P_{\min}$ is the minimum level of wanted signal required to meet the minimum performance criteria as defined in clause 4.3.1.12.3 in the absence of any blocking signal. NOTE 3: The level specified is the level at the UUT receiver input assuming a 0 dBi antenna assembly gain. In case of conducted measurements, this level has to be corrected for the (in-band) antenna assembly gain (G). In case of radiated measurements, this level is equivalent to a power flux density (PFD) in front of the UUT antenna with the UUT being configured/positioned as recorded in clause 5.4.3.2.2.			

#### 14.3 Test Procedure

Refer to ETSI EN 300 328 V2.2.0 Clause 5.4.11.



## 14.4 Test Results

Mode	Wanted Power(dBm)	Blocking Frequency (MHz)	Blocking Power(dB)	Measured PER (%)	Limit (%)
GFSK	-74	2380	-34	0.01	10
	-74	2504	-34	0.01	10
	-74	2300	-34	0.01	10
	-74	2584	-34	0.01	10
PI/4DQPSK	-74	2380	-34	0.01	10
	-74	2504	-34	0.01	10
	-74	2300	-34	0.01	10
	-74	2584	-34	0.01	10
8DPSK	-74	2380	-34	0.01	10
	-74	2504	-34	0.01	10
	-74	2300	-34	0.01	10
	-74	2584	-34	0.01	10



## 15. GEO-LOCATION CAPABILITY

### 15.1 Definition and Requirements

Geo-location capability is a feature of the equipment to determine its geographical location with the purpose to configure itself according to the regulatory requirements applicable at the geographical location where it operates.

The geo-location capability may be present in the equipment or in an external device (temporary) associated with the equipment operating at the same geographical location during the initial power up of the equipment. The geographical location may also be available in equipment already installed and operating at the same geographical location.

### 15.2 Test Results

This product doesn't support Geo-location.



## 16. SETUP PHOTOGRAPHS

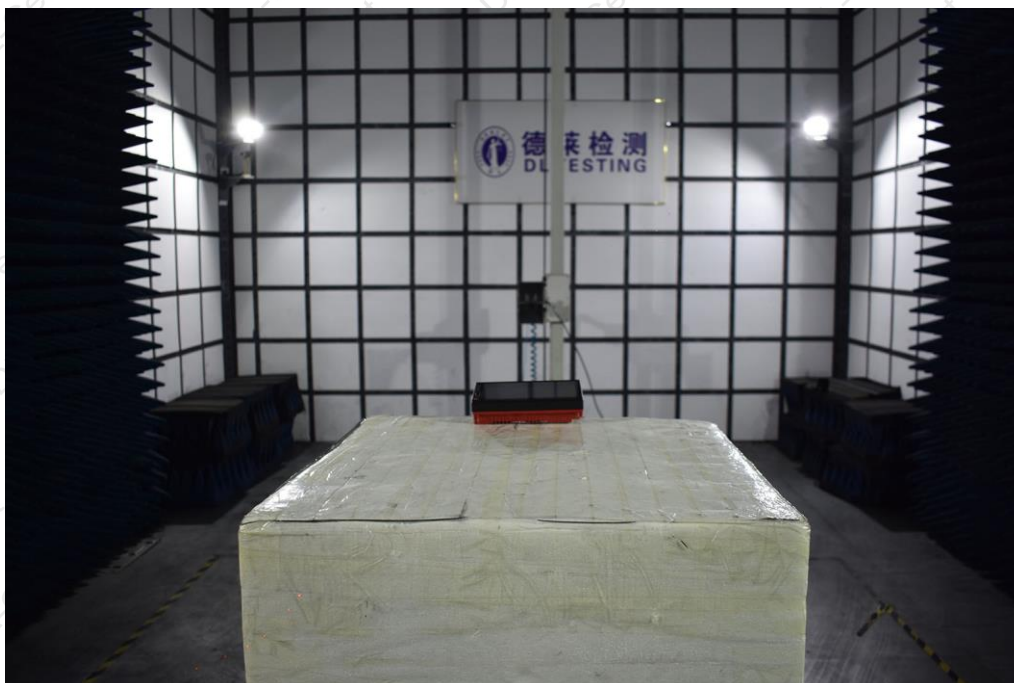
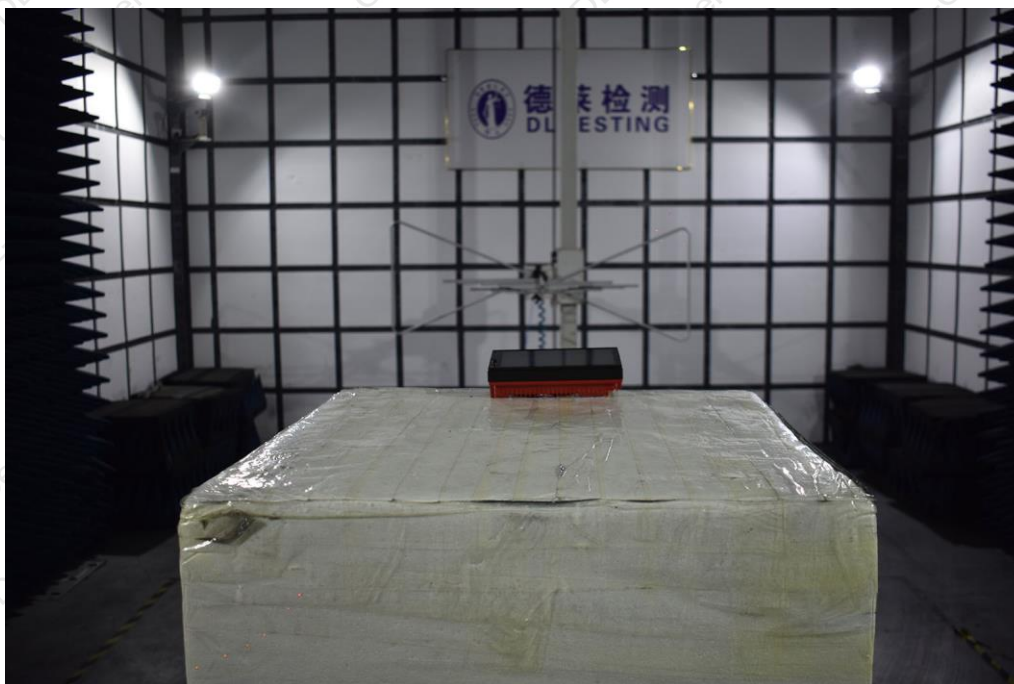

## 17. EUT PHOTOGRAPHS

Please see EMC test report.

\*\*\*\*\* END OF REPORT \*\*\*\*\*